

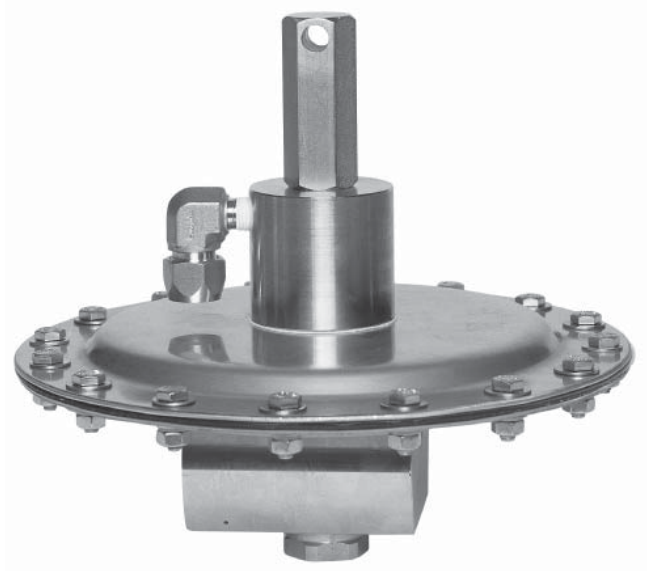

# Model 1088

## Vacu-Gard® Tank Blanketing Valve

### 1/2" (DN15)



1/2" Model 1088

### Application

On many low-pressure storage tanks the operating range is very low, which makes blanketing and venting system selection/design a challenge for the engineer. The Vacu-Gard® makes the job much easier. First, the Vacu-Gard® set point definition is where the blanketing valve closes bubble tight. This gives the largest dead band between the blanketing valve set point and the set point of the relieving device, and therefore will reduce losses. Second, the Vacu-Gard® has a wide range of available settings, from vacuum to 14 psig, that make proper selection easier.

The Model 1088 is a valve specifically designed for small tank blanketing applications. It opens and closes automatically as required, to maintain a closely controlled blanket pressure. Standard valve material provides added corrosion protection at no additional cost. The simple design increases reliability and lowers maintenance cost.

### FEATURES

- Versatile:** Single valve system offers wide variety of configurations to meet every blanketing application. Self cleaning flow design.
- Bottom entry Design:** Compact and light weight yet allows complete access to the valve internals without being removed from the tank. Only time the diaphragm case needs to be disassembled is when replacing the diaphragm.
- Stability:** Pressure balanced trim. Fluctuations in supply pressure does not affect set point.
- Performance:** Valve set point can be verified 100% on the tank, without removal and without flowing supply gas into the tank. Temperature changes have no appreciable effect on set point.
- Shutoff:** Bubble tight at set point, prevents waste of blanketing gases.
- Lower Maintenance Costs:** Uses standard o-rings for seat and seals.



## GENERAL SPECIFICATIONS

### Sizes

1/2" (DN15)

### Connections

1/2" FNPT (screwed)  
 1/2" 150# RF threaded flanges & nipples  
 3/4", 1" 150# RF threaded reducing flanges & nipples  
 Larger size reducing flanges and special configurations are available on request:  
 DN15 (PN40) flanges.  
 "Tri-Clamp®".

### Outlet Configurations

Horizontal or Vertical

Valves with FNPT or threaded nipple and flange connections can be configured in the field. Special configuration must be specified at time of order placement.

### Sensing Options

Remote sensing  
 Integral dip tube sensing (Vertical Outlet Only)  
 Internal sensing

### Supply Pressures

Minimum: 10 psig (.69 Bar)  
 Maximum: 200 psig (13.83 Bar)

### Capacities

**Remote Sensing:** use flow capacity values listed in Table 6.

**Internal Sensing:** multiply flow capacity values in Table 6 by 25 %.

### Pressure - Temperature Specifications

Body Material	End Connection	Inlet Pressure	Temperature F(C)*
316 Stainless Steel	NPT & 300# Flange	200 psig (13.8 Barg)	-50 to 400 (-45 to 204)
	150# Flange	200 psig (13.8 Barg)	-325 to 300 (-198 to 149)
		195 psig (13.4 Barg)	-325 to 400 (-198 to 204)

\* Design temperature limits maybe restricted by trim selection

### Outlet Pressure Ranges

See Table 3

### Maximum Back Pressures

25 psig (1.7 Bar) – standard  
 Higher pressures on request

### Materials of Construction

Diaphragm Case Material:  
 Carbon Steel (Powder Coated)  
 Stainless Steel  
 Trim Material:  
 316 SST  
 Diaphragm Material:  
 PTFE  
 Soft Seat & Seals:  
 FKM – standard,  
 Buna-N, EPDM,  
 FFKM 1 - Similar to Chemraz  
 FFKM 2 - Similar to Kalrez

### Temperature Limits

Seat & Seal Materials  
 FKM (Fluorocarbon Elastomer):  
 -15° to 300° F (-26° to 149° C)  
 Buna-N (Nitrile-NBR):  
 -40° F to 212° F (-40° C to 100° C)  
 EPDM (Ethylene propylene):  
 -55° F to 212° F (-48° C to 100° C)  
 FFKM 1 (Perfluoroelastomer):  
 -22° F to 400° F (-30° C to 204° C)  
 FFKM 2 (Perfluoroelastomer):  
 -40° F to 400° F (-40° C to 204° C)

### Paint

Standard: Exterior coating will be a combination of Cashco Paint Specs #S-1777 epoxy and #S-1743 powder coated. Tubing, fasteners, - corrosion resistant parts excluded.

Alternate Paint: See Opt-95OS.

## CAPACITY REQUIREMENTS

The capacity requirement of the tank blanketing valve is the sum of two components. The first being inbreathing due to liquid or product movement out of the tank and the second being inbreathing due to contraction of the vapors/product because of weather changes.

Inbreathing due to maximum liquid or product movement out of the tank equals 8.0 SCFH of air for each US gallon per minute of maximum emptying rate or 0.94 Nm<sup>3</sup>/h of air for each m<sup>3</sup>/h of maximum emptying rate.

$$Q \text{ displacement (SCFH)} = \text{Max. Pumpout Rate (gpm)} \times 8.0$$

or

$$Q \text{ displacement (Nm}^3\text{/h)} = \text{Max. Pumpout Rate (m}^3\text{/h)} \times .94$$

The second component, inbreathing due to weather changes, is selected from Table 5 (Table 5A). The tank capacity is found in column 1 and the corresponding inbreathing requirement is selected from column 2.

The two components are added together to give the total inbreathing requirement and the capacity requirement of the tank blanketing valve.

$$Q \text{ total} = Q \text{ displacement} + Q \text{ thermal}$$

## VALVE SELECTION

If the tank blanketing supply pressure varies, use the minimum supply pressure in selecting the tank blanketing valve and the maximum supply pressure to determine blanketing valve failure capacity. Go to Table 6 to determine the capacity at the minimum supply pressure. This capacity must be equal to or greater than the Total Inbreathing Requirement (Q total). Next determine if a reducing "flow plug" can be used to make the capacity of the tank blanketing valve more closely match the inbreathing requirements. This will also reduce the fail open capacity of the blanketing valve. This is done by dividing the required inbreathing (Q total) by the full capacity of the size valve selected and multiplying by 100. Now from Table 2 choose the flow plug that is greater than the calculated percentage.

Example:

Total inbreathing requirement (Q total) = 1,000 SCFH  
 Maximum supply pressure = 100 psig  
 Minimum supply pressure = 80 psig  
 The 1088 flows 1,318 SCFH at 80 psig.

At the maximum supply pressure of 100 psig, use Cv of 1.1 or fail open flow, which is needed when sizing the pressure relieving device.

## NORMAL INSTALLATION

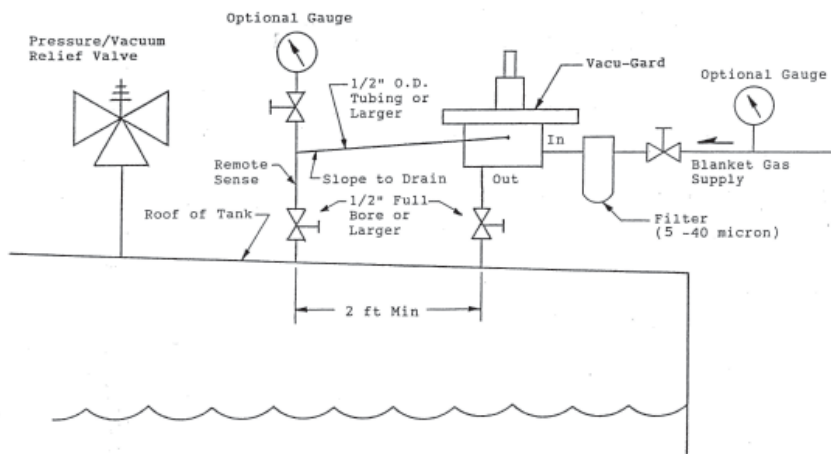

TABLE 1						
STANDARD MATERIALS OF CONSTRUCTION						
SIZE	MAIN BODY *	DIAPHRAGM CASES	SPRING BONNET	VALVE TRIM	SENSE DIAPHRAGM	SPRING (2 places)
1/2"	316 SST (C)	CS	CS	316 SST	Teflon®	302 SST
	316 SST (S)	304 SST **	304 SST			
	316 SST (W)	CS (upper)				
		304 SST (lower) **				

\* Character within ( ) is material code from Position 5 of Coder.  
 \*\* 316 SST for NACE Construction.

TABLE 2	
Cv Values	
Normal Flow	Fail Open Flow
0.4	1.1

TABLE 3	
OUTLET PRESSURE RANGES	
0.75" to 1.5" WC	(1.9 - 3.72 mbar)
1.5" - 5.0" WC	(3.72 - 12.4 mbar)
5" to 14" WC	(12.4 - 34.8 mbar)
14" to 30" WC	(34.8 - 74.7 mbar)
1.0 to 1.5 psig	(69 - 103 mbar)
1.5 to 3.0 psig	(103 - 207 mbar)
3.0 to 14.0 psig	(0.2 - 0.96 bar)
1" to 1-1/2" WC (vac)	(2.5 - 3.7 mbar)
1-1/2" to 6" WC (vac)	(3.7 - 14.8 mbar)

TABLE 4	
SET POINT	MAXIMUM INLET PRESSURE MODEL 1088 (Consult Factory for Higher Inlet Pressures)
0.75" - 1.00" w.c. (1.9 - 2.5 mbarg)	75 psig (5.2 barg)
1.05" - 14" w.c. (2.6 - 34.5 mbarg)	125 psig (8.6 barg)
0.51 - 14.0 psig (0.035 - 0.96 barg)	200 psig (13.8 barg)
INLET PRESSURE	
RECOMMENDED	≥ 20 psig (1.38 barg)

## VALVE OPERATION

The Vacu-Gard Model 1088 is a direct spring-operated pressure reducing valve. Below demonstrates the three sensing options available.

Set pressure is defined as the pressure at which the valve will be fully closed on increasing tank pressure during a normal operating cycle to inject needed blanket gas. Whenever the pressure in the sense chamber falls below the set pressure, the set pressure spring located above the sense diaphragm will push downward to unseat the spindle. This will allow inlet pressure to flow across the spindle seat and out through the outlet port. When the pressure in the sense chamber is sufficient to overcome the force of the set pressure spring the spindle will move upward to close the seat and stop the flow.

The internal sensing valve senses the outlet pressure just downstream of the seat. The flow here is very turbulent. This results in a pressure reading higher than actual tank pressure resulting in reduced flow capacity. This is most noticeable at low setpoints.

The integral dip-tube sensing valve senses the tank pressure through the use of a dip-tube that must protrude a minimum of 6" below the tank roof. See OPTIONAL FEATURES & ACCESSORIES.

The remote sensing valve senses the tank pressure remotely through the remote sense port.

The sense chamber is not a dead ended chamber. therefore, whenever the valve is open, there is a very small flow from the seat up into the sense chamber. Any pressure that gets into the sense chamber from this path must be able to get out rapidly through the sense port, otherwise, a build up of pressure in the sense chamber will occur, causing the valve to close prematurely. For this reason, remote sense lines and valve discharge piping must be large enough to carry away this pressure.

## Model 1088 Vacu-Gard Tank Blanketing Valve Sensing Options

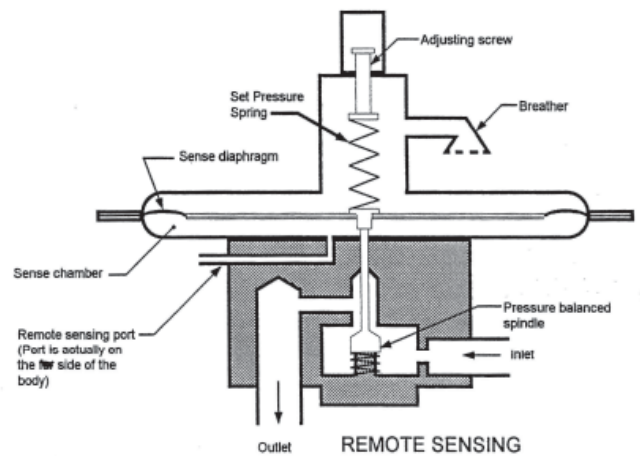
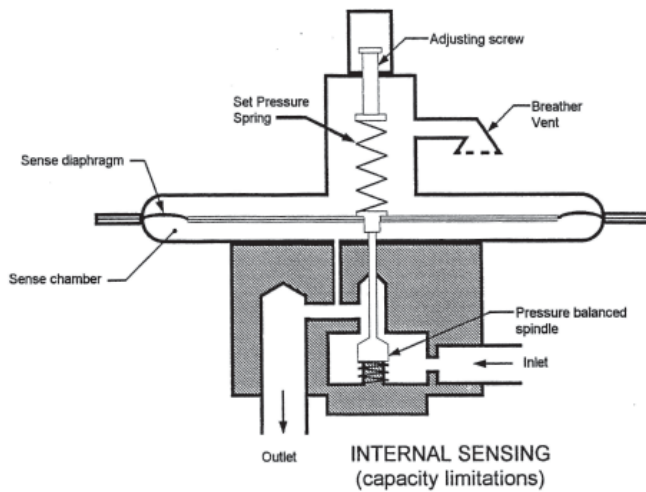

### STANDARD INFORMATION

**The tank blanketing valve is not a substitute for the vacuum relief device.**

API Standard 2000 states, "The design of a gas-repressuring system to eliminate the requirement for vacuum relief valves is beyond the scope of this standard and should be considered only when the induction of air represents a hazard equal to or greater than failure of the tank".

**The tank blanketing valve failure must be taken into account when considering possible causes of overpressure in a tank.**

API Standard 2000 states, "When the possible causes of overpressure or vacuum in a tank are being determined, other circumstances resulting from equipment failures and operating errors must be considered and evaluated by the designer." Failure of the tank blanketing valve can result in unrestricted gas flow into the tank, reduced gas flow or complete loss of the gas flow.

**Tank blanketing valve set point definition is not the same for all manufacturers.**

Valve Concepts defines set point as the point where the tank blanketing valve is closed bubble tight!

Some manufacturers define the set point as where the blanketing valve opens and the valve requires a pressure above the set point in order to close completely. Others define set point somewhere in between opening and closing but still the pressure must go above the defined set point in order to close completely.

The following example illustrates Valve Concepts definition of set point.

1088-TB

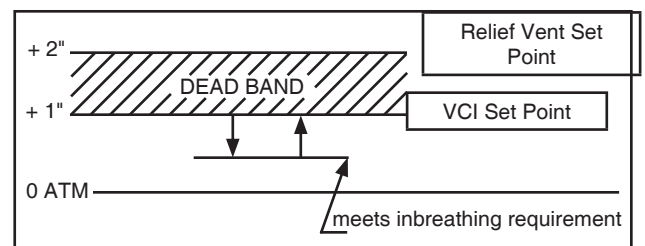
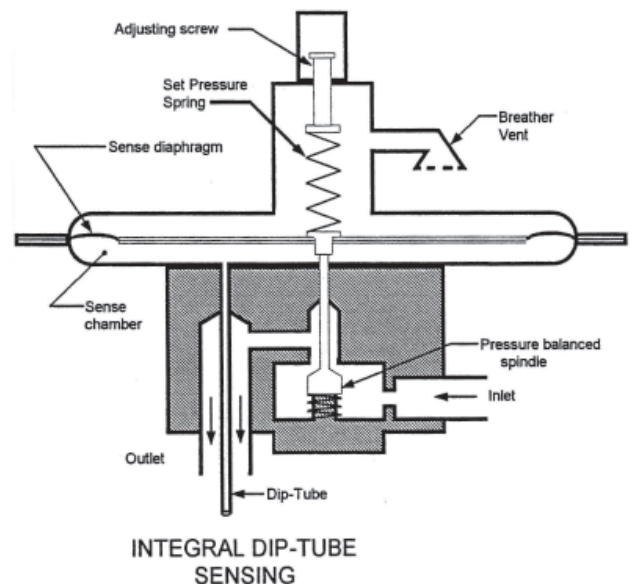

As can be seen from the illustration, the Vacu-Gard gives the greatest dead band between the blanketing valve set point and the relief vent set point.

TABLE 5					
REQUIREMENTS FOR THERMAL INBREATHING - ENGLISH UNITS (AIR)					
(Column 1)		(Column 2)	(Column 1)		(Column 2)
TANK CAPACITY		INBREATHING	TANK CAPACITY		INBREATHING
Barrels	Gallons	SCFH	Barrels	Gallons	SCFH
60	2,500	60	35,000	1,470,000	31,000
100	4,200	100	40,000	1,680,000	34,000
500	21,000	500	45,000	1,890,000	37,000
1,000	42,000	1,000	50,000	2,100,000	40,000
2,000	84,000	2,000	60,000	2,520,000	44,000
3,000	126,000	3,000	70,000	2,940,000	48,000
4,000	168,000	4,000	80,000	3,360,000	52,000
5,000	210,000	5,000	90,000	3,780,000	56,000
10,000	420,000	10,000	100,000	4,200,000	60,000
15,000	630,000	15,000	120,000	5,040,000	68,000
20,000	840,000	20,000	140,000	5,880,000	75,000
25,000	1,050,000	24,000	160,000	6,720,000	82,000
30,000	1,260,000	28,000	180,000	7,560,000	90,000

**NOTE:** Table and sizing from API 2000 Seventh Edition, annex A, March 2014.

TABLE 5A			
REQUIREMENTS FOR THERMAL INBREATHING - METRIC UNITS (AIR)			
(Column 1)	(Column 2)	(Column 1)	(Column 2)
TANK CAPACITY	INBREATHING	TANK CAPACITY	INBREATHING
CUBIC METERS	Nm3/H	CUBIC METERS	Nm3/H
10	1.69	5000	787
20	3.37	6000	896
100	16.9	7000	1003
200	33.7	8000	1077
300	50.6	9000	1136
500	84.3	10000	1210
700	118	12000	1345
1000	169	14000	1480
1500	253	16000	1615
2000	337	18000	1745
3000	506	20000	1877
3180	536	25000	2179
4000	647	30000	2495

**NOTE:** Table and sizing from API 2000 Seventh Edition, annex A, March 2014.

The contents of this publication are presented for informational purposes only, and while every effort has been made to ensure their accuracy, they are not to be construed as warranties or guarantees, express or implied, regarding the products or services described herein or their use or applicability. We reserve the right to modify or improve the designs or specifications of such product at any time without notice.

Cashco, Inc. does not assume responsibility for the selection, use or maintenance of any product. Responsibility for proper selection, use and maintenance of any Cashco, Inc. product remains solely with the purchaser.

TABLE 6			
TANK BLANKETING VALVE CAPACITIES For REMOTE SENSING *			
INLET PRESSURE psig (Bar)	PLUG SIZE CAPACITIES IN SCFH (Nm <sup>3</sup> /h) FOR AIR		
	10%	40%	100%
10 (.7)	28 (.7)	112 (3.0)	280 (7.5)
20 (1.4)	45 (1.2)	181 (4.8)	452 (12.1)
30 (2.1)	60 (1.6)	241 (6.4)	602 (16.1)
40 (2.8)	74 (2.0)	299 (8.0)	747 (20.0)
50 (3.4)	89 (2.3)	356 (9.5)	891 (23.9)
60 (4.1)	103 (2.7)	414 (11.1)	1,035 (27.7)
70 (4.8)	117 (3.1)	471 (12.6)	1,177 (31.5)
80 (5.5)	131 (3.5)	527 (14.1)	1,318 (35.3)
90 (6.2)	146 (3.9)	584 (15.6)	1,460 (39.1)
100 (6.9)	160 (4.3)	639 (17.1)	1,599 (42.9)
110 (7.6)	174 (4.6)	697 (18.7)	1,742 (46.7)
120 (8.3)	188 (5.0)	752 (20.1)	1,882 (50.4)
130 (9.0)	202 (5.4)	809 (21.6)	2,023 (54.2)
140 (9.6)	216 (5.8)	865 (23.1)	2,164 (58.0)
150 (10.3)	230 (6.1)	921 (24.7)	2,303 (61.7)
160 (11.0)	244 (6.5)	978 (26.2)	2,445 (65.5)
170 (11.7)	258 (6.9)	1034 (27.7)	2,585 (69.3)
180 (12.4)	272 (7.3)	1090 (29.2)	2,726 (73.1)
190 (13.1)	286 (7.6)	1147 (30.7)	2,867 (76.8)
200 (13.8) MAX	300 (8.0)	1202 (32.2)	3,005 (80.5)
INLET PRESSURE psig (Bar)	PLUG SIZE CAPACITIES IN SCFH (Nm <sup>3</sup> /h) FOR NITROGEN		
	10%	40%	100%
10 (.7)	28 (.7)	114 (3.0)	284 (7.6)
20 (1.4)	46 (1.2)	183 (4.9)	459 (12.3)
30 (2.1)	61 (1.6)	245 (6.5)	614 (16.4)
40 (2.8)	76 (2.0)	305 (8.2)	762 (20.4)
50 (3.4)	91 (2.4)	364 (9.7)	910 (24.3)
60 (4.1)	105 (2.8)	422 (11.3)	1,056 (28.3)
70 (4.8)	120 (3.2)	480 (12.9)	1,201 (32.2)
80 (5.5)	134 (3.6)	537 (14.4)	1,344 (36.0)
90 (6.2)	149 (4.0)	596 (16.0)	1,489 (40.0)
100 (6.9)	163 (4.3)	653 (17.5)	1,632 (43.7)
110 (7.6)	178 (4.7)	711 (19.0)	1,778 (47.6)
120 (8.3)	192 (5.1)	768 (20.6)	1,921 (51.5)
130 (9.0)	206 (5.5)	826 (22.1)	2,065 (55.3)
140 (9.6)	221 (5.9)	883 (23.7)	2,208 (59.2)
150 (10.3)	235 (6.3)	940 (25.2)	2,351 (63.0)
160 (11.0)	249 (6.7)	998 (26.7)	2,495 (66.9)
170 (11.7)	264 (7.1)	1055 (28.2)	2,638 (70.7)
180 (12.4)	278 (7.4)	1113 (29.8)	2,782 (74.5)
190 (13.1)	292 (7.8)	1170 (31.3)	2,925 (78.4)
200 (13.8) MAX	307 (8.2)	1227 (32.9)	3,067 (82.2)

\* Note: For INTERNAL SENSING use 1/4 of values shown.

## 1/2" NPT Horizontal Connection

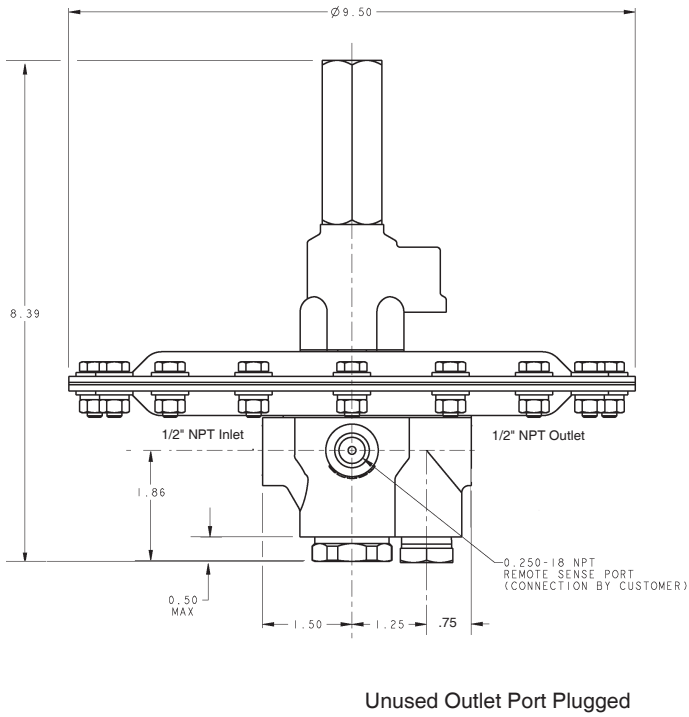

FIGURE 1

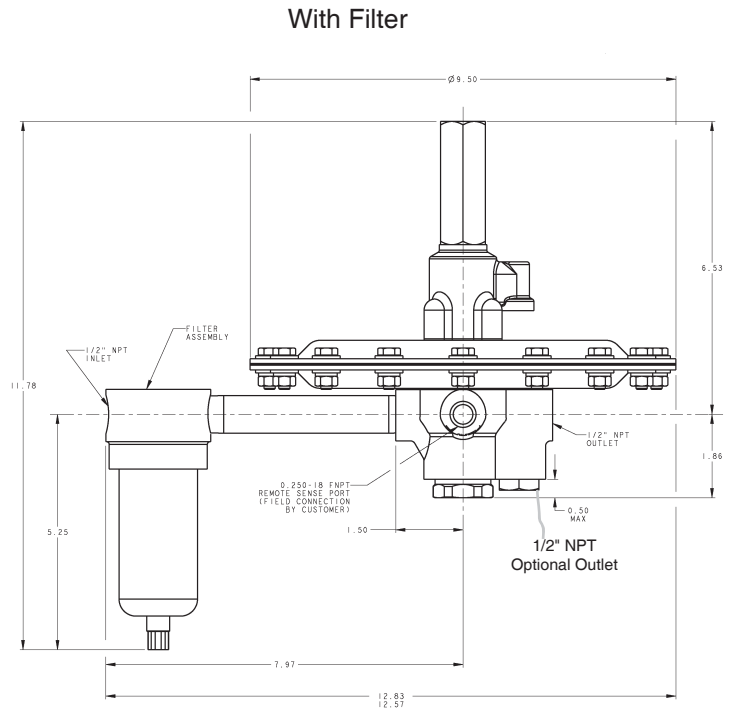

FIGURE 2

## 1/2" 150# RF Flange Vertical Connection with Gauge

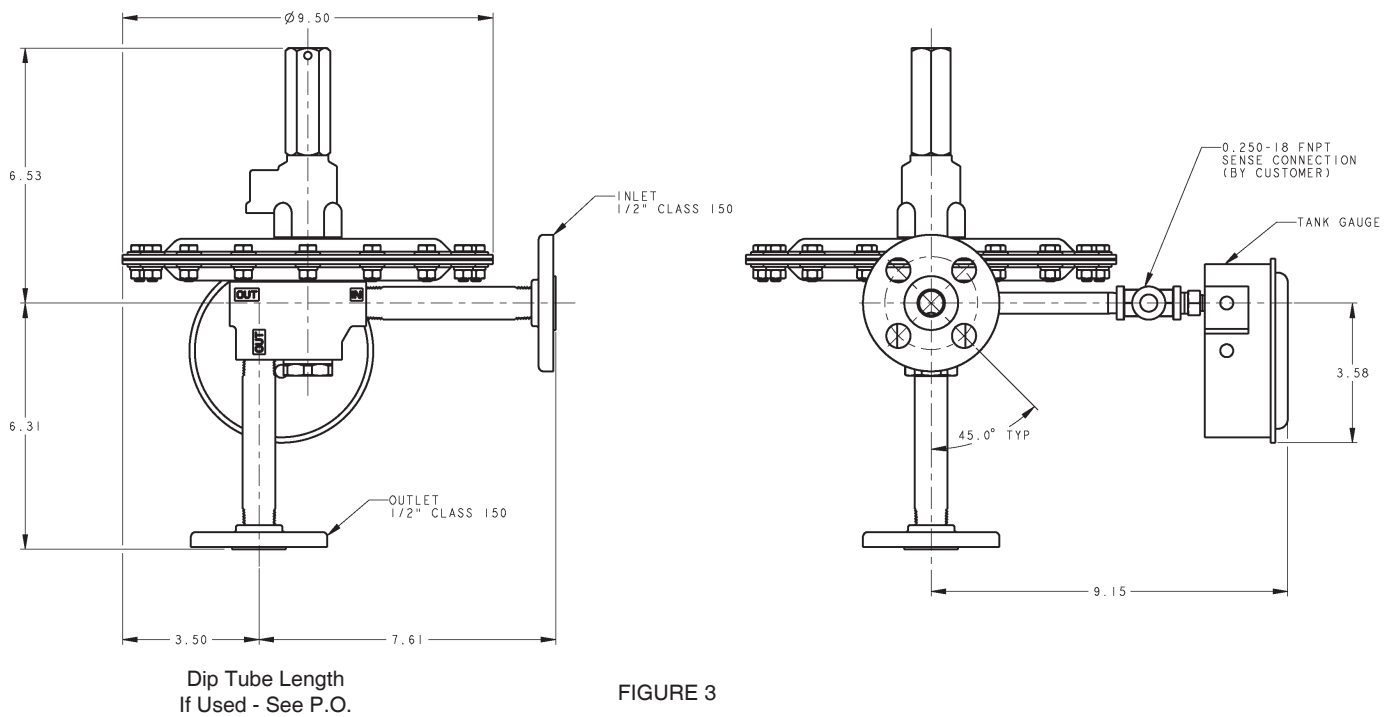

FIGURE 3



### 1/2" 150# RF Flange Horizontal Connection with Gauge

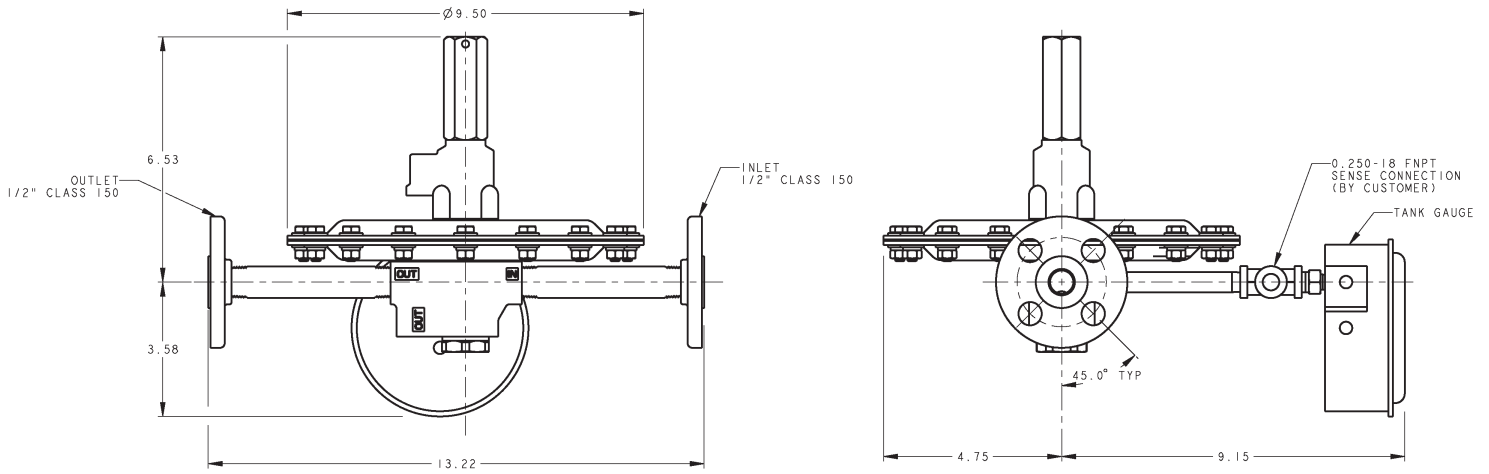

FIGURE 4

**Approximate Weight**  
FNPT:  
 12 lbs (5.4 kg)  
Flanged:  
 17 lbs (7.7 kg)

### 1" 150# Reducing Flange Vertical Connection with Filter and Gauge

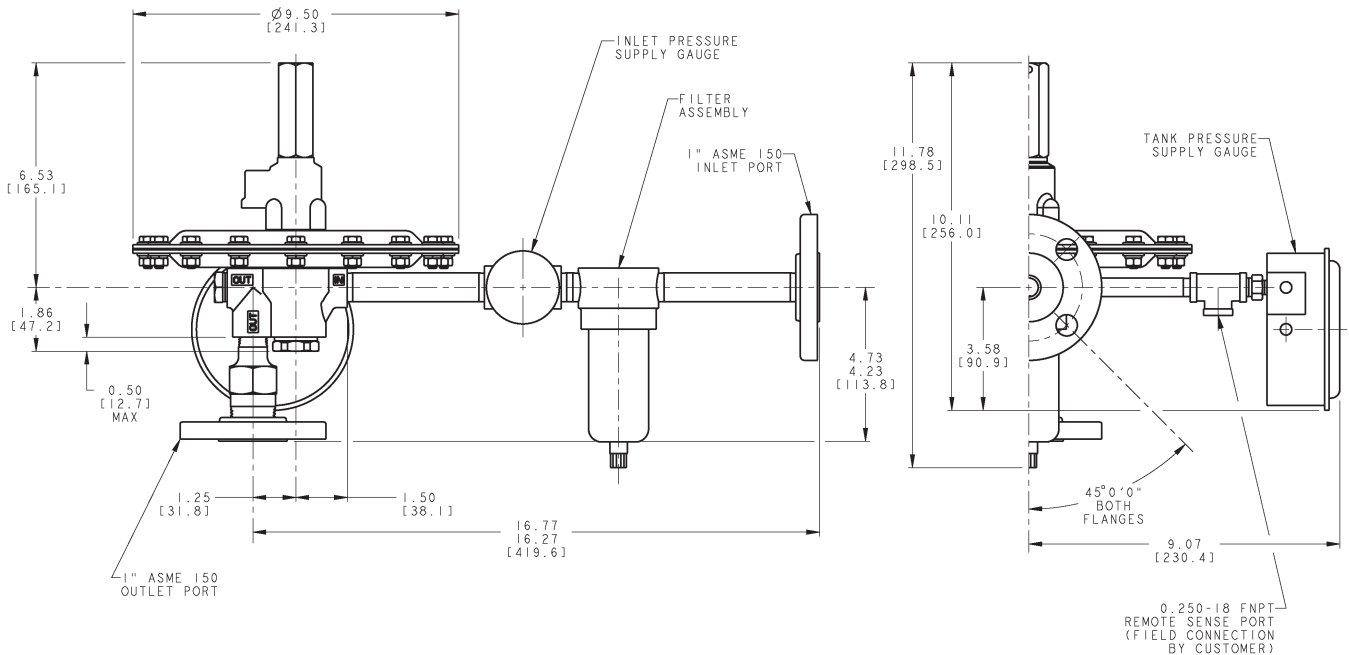

FIGURE 5

### 3/4" 150# RF Flange Horizontal Connection

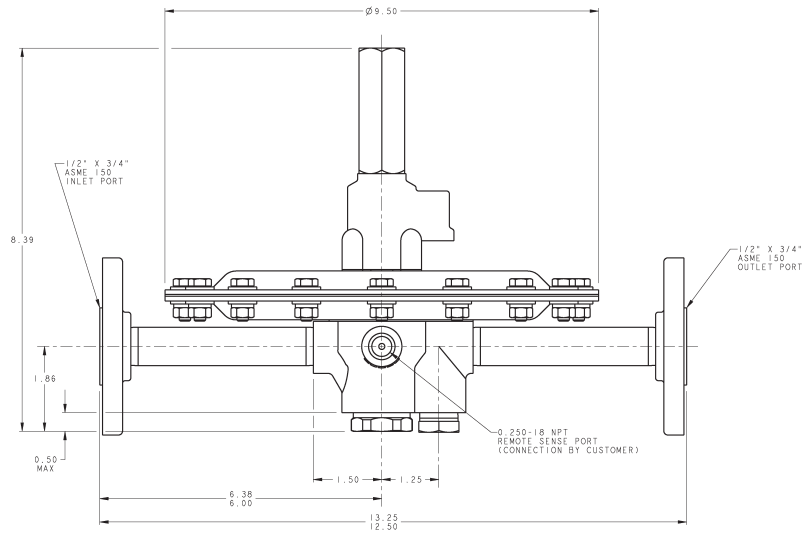

FIGURE 6

### 1" 150# RF Flange Vertical Connection

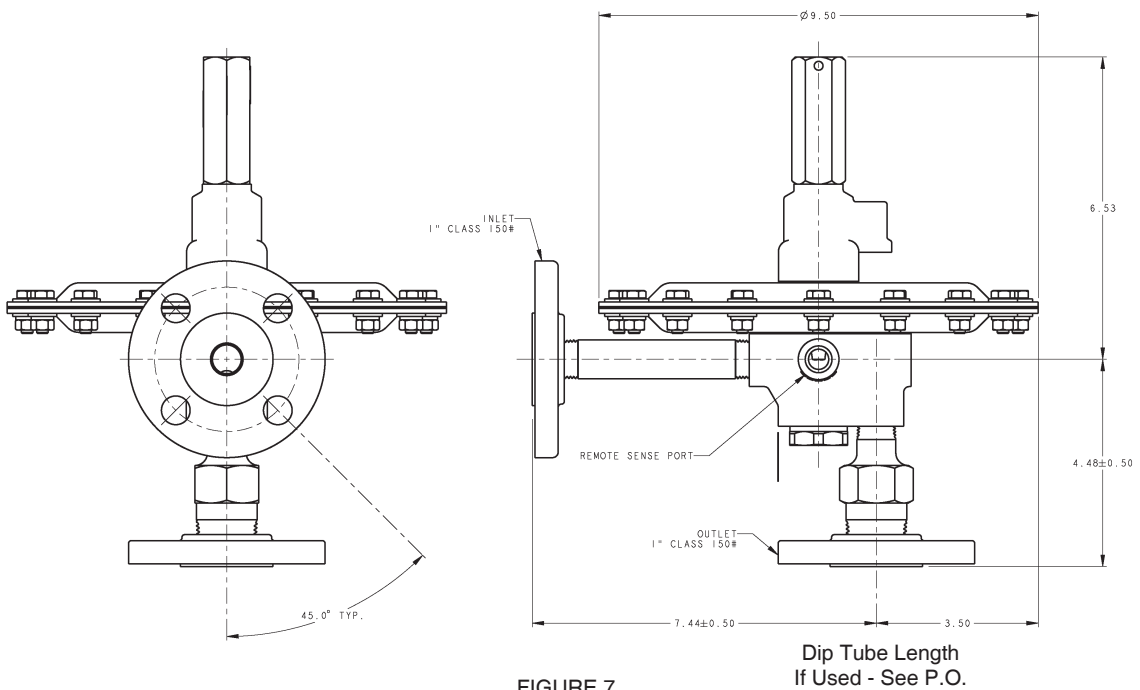

FIGURE 7

Dip Tube Length  
If Used - See P.O.

## OPTIONAL FEATURES & ACCESSORIES

### Supply Pressure Gauge

To provide local indication of supply pressure.

- Standard ABS gauge with carbon steel fitting.
- Stainless gauge with 316 SST fitting.

### Control Pressure Gauge

To provide local indication of actual tank pressure.

- Standard Magnehelic® gauge with carbon steel fitting.
- Stainless gauge with 316 SST fitting.

### Purge

A purge is used to prevent tank vapors from entering into the valve. One Variable Area Flow meter (Rotameter) is used to purge both the sense line and the outlet. The combined flow is 1 - 1.5 SCFH. VCI advises the use of a purge when tank vapors may solidify or crystallize when cooled to ambient temperature.

A purge will also extend the service life of the valve if 316 SST is not compatible with the tank vapors.

- Standard Rotameter used has a 316 SST body with glass tube.

### PV-Gard Manifold

The PV-Manifold allows for a very compact installation of a blanketing valve and vent valve on one single tank nozzle. Normally, an installation of this type requires at least three different nozzles; one for the blanketing valve, one for the vent valve, and one for the remote sensing for the blanketing valve. Using the PV-Manifold, only one tank nozzle is required.

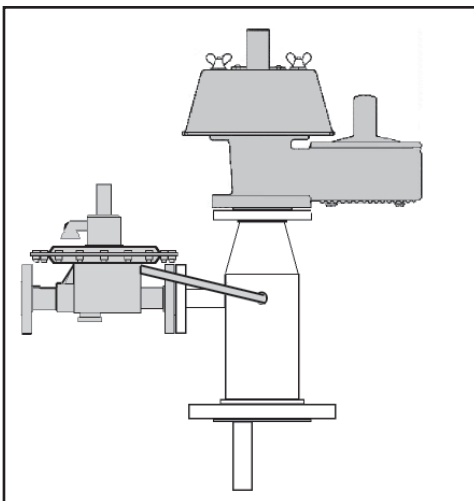

### Sense with Dip Tube (patented)

This option provides a sense connection into the tank through the **vertical outlet** of the valve. This can be useful when no tank connection is available for the standard remote sense.

- The dip tube length should be sized so that it protrudes 6" to 8" below the tank roof into the tank.
- The dip tube diameter is 0.375" (9.52 mm).
- Standard material is 316 SST.

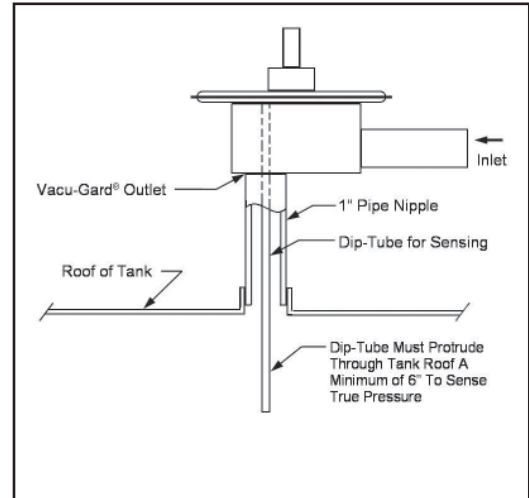

**NOTE: Customer must specify length of Dip Tube .**

### Inline Filter

The use of an inline filter is not required for regular blanketing gases. An inline strainer or filter can be provided in case the blanketing gas used is not sufficiently clean.

**Option -40:** NACE CONSTRUCTION. Internal wetted portions meet NACE standard MR0175, when exterior of the vent is not directly exposed to a sour gas environment, buried, insulated or otherwise denied direct atmospheric exposure. SST body and Trim - Buna-N or FKM Seat and Seal materials only. NPT or Flanged Connection. (Flanged version requires post-weld stress relieving by heat treating.)

**Option -950S:** OFFSHORE installations. Coating of all exterior surfaces will be per Cashco Paint Specs #S-1777 epoxy. Tubing, fasteners, - corrosion resistant parts excluded. Painting of tubing and fasteners optional upon special request.

**Model 1088 PRODUCT CODE** 09/01/15  
**SPRING OPERATED VACU-GARD®**

Last 6 Characters reserved for SPQ drawing numbers assigned by Cashco Inc.  
 (Format as - # # # # #)

**S** **O** POS 3 POS 4 POS 5 POS 6 POS 7 POS 8 POS 9 POS 10 POS 11 **B** **0** **0** **0** **0** **0** **0**

POSITION 3 - OUTLET (Sensing)	
Outlet	CODE
Horizontal (Internal) *	G
Horizontal (Remote)	J
Vertical (Internal) *	P
Vertical (Remote)	R
Vertical (Integral Dip-Tube)	W

**Must indicate length of dip tube in Special Instructions on Order Entry Transmittal Form & on Customer PO.** See pg. 11.  
 \* Internal Sensing capacity is 25% of Remote Sensing. See pg. 8.

POSITION 4 - Product Classification Under European "Pressure Equipment Directive"		
PRODUCT DESTINATION	HAZARD CATEGORY	CODE
Anywhere except Europe	N/A	0
European Countries *	Sound Engineering Practice (SEP)	S
	ATEX	A

\* For products to be placed in service in Europe. Ref to Directive 97/23/EC.  
 Forward Completed "EU" Application Recorder prior to quotation. (Without Recorder- Processing of Purchase Order will be delayed).  
 Contact Cashco for Assistance.

POSITION 5 - MATERIALS CONSTRUCTION	
Body/Trim/Diaphragm Case Material	CODE
SST Body, Trim W/CS Diaphragm Case <sup>1</sup>	C
SST Body, Trim & Diaphragm Case <sup>2</sup>	S
SST Body, CS Upper Diaphragm Case, All Wetted Surface SST <sup>2</sup>	W
SST Body, Trim & Diaphragm Cases, External and Internal surfaces are Electro-Polished	E

<sup>1</sup> When Fittings & Gauges are req'd, select pressure ranges from Position 6. Assembled blanket valve will include CS Fittings, Standard Supply Gauge and Low Pressure Alum. Magneheic® Tank Pressure gauge.  
<sup>2</sup> When Fittings & Gauges are req'd, select pressure ranges from Position 6. Assembled blanket valve will include SST Fittings, SST Supply Gauge and Low Pressure Alum. Magneheic® Tank Pressure Gauge.

POSITION 6 - GAUGE OPTION								CODE
No Gauges								0
Supply Pressure Gauge Range psig	Supply Gauge ONLY	Supply Pressure Gauge plus Tank Gauge for Low Pressure Range						CODE
		0 - 5"wc (0 - 15 mbar)	0 - 10"wc (0 - 25 mbar)	0 - 15"wc (0 - 40 mbar)	0 - 1psig (0 - 80 mbar)	0 - 5psig (0 - 350 mbar)	0 - 15psig (0 - 1.03 barg)	
CODE	CODE	CODE	CODE	CODE	CODE	CODE	CODE	CODE
0 - 100	1	A	D	G	K	N	S	W
0 - 160	2	B	E	H	L	P	T	Y
0 - 200	3	C	F	J	M	R	V	#
NO Supply Gauge	4	5	6	7	8	9		Z

POSITION 7 - END CONNECTIONS	
End Connection	CODE
3/4" - 150# RF Reducing Flanges w/nipples	2
1" - 150# RF Reducing Flanges w/nipples	3
1/2" - 150# RF Flanges w/nipples	A
"Tri-Clamp®"	S
1/2" FNPT	T

POSITION 8 - FLOW PLUG SIZE	
Sizes	CODE
10%	1
40%	4
100%	C

POSITION 9 - SEATS & SEALS	
Material	CODE
Buna-N *	B
FFKM 1	C
EPDM	E
FFKM 2	K
FKM (std) *	V
FKM (Phar)	P

\* Use with NACE Construction.

POSITION 10- RANGE SPRINGS	
Spring Range	CODE
0.75" - 1.5" wc (1.9-3.72 mbar)	2
1.5" - 5.0" wc (3.72-12.4 mbar)	3
5" - 14" wc (12.4-34.8 mbar)	6
14" - 30" wc (34.8-74.7 mbar)	7
1 - 1.5 psig (69-103 mbar)	8
1.5 - 3 psig (103-207 mbar)	9
3 - 14 psig (0.2-0.96 bar)	H
1" - 1.5" wc vac (2.5-3.72 mbar) *	A
1.5" - 6" wc vac (3.72-14.8 mbar) *	C

\* SST Tank gauge is not available for these ranges.

POSITION 11 - EXTERNAL FILTER		
Description	Std. Paint	Opt-95OS
	CODE	CODE
No Filter (Standard)	0	4
SST Filter w/Purge	A	6
Alum/Zinc Filter w/Check Valve	C	-
SST Filter w/Check Valve	D	8
Opt-40 NACE Const. Per MR0175 - No Filter	3	9
Opt-40 NACE Const. Per MR0175 - w/SST Filter	5	U
Opt-40 NACE Const. Per MR0175 - w/SST Filter with Purge	2	7
Purge, No Filter	N	K
Alum/Zinc Filter w/Purge	P	-
SST Filter	S	T
Alum/Zinc Filter	W	-

For Special Construction Other Than Above Contact Cashco for Special Product Code

Cashco, Inc.  
 P.O. Box 6  
 Ellsworth, KS 67439-0006  
 PH (785) 472-4461  
 Fax. # (785) 472-3539  
 www.cashco.com  
 email: sales@cashco.com  
 Printed in U.S.A. 1088-TB

Cashco GmbH  
 Handwerkerstrasse 15  
 15366 Hoppegarten, Germany  
 PH +49 3342 30968 0  
 Fax. No. +49 3342 30968 29  
 www.cashco.com  
 email: germany@cashco.com

Cashco do Brasil, Ltda.  
 Al.Venus, 340  
 Indaiatuba - Sao Paulo, Brazil  
 PH +55 11 99677 7177  
 Fax. No.  
 www.cashco.com  
 email: brazil@cashco.com