

# Data Sheets Manual

## Gate Valves

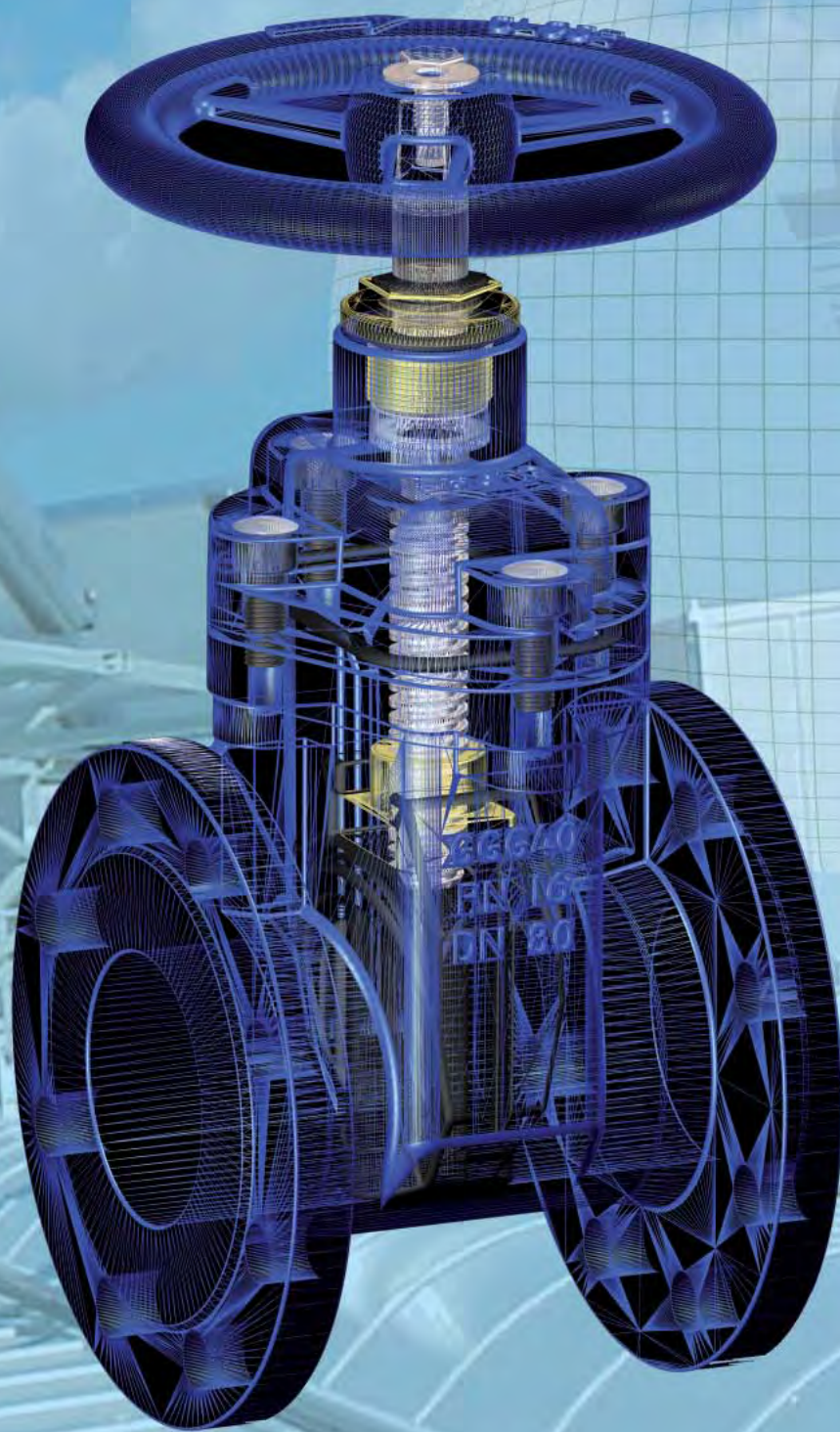





# GATE VALVES

## Index

Engineering Data	5-9
General Design Considerations	10-11
Flow Data	12
Soft Seat Gate Valve, series 504/505	13
- Attributes of Design	13
-Parts and Materials	14
-Dimensions	15-17
Soft Seat Gate Valve, series 507	18
-Attributes of Design	18
-Parts and Materials	19
-Dimensions	20
-Working Parameters	21
Closing torque and number of turns, series 504/505/507	22
Metal seat Gate Valve, series 31,32,33	23
-Attributes of Design	23
-Parts and Materials	24
-Dimensions	25
-Working Parameters	26
Actuation and Accesories	27
Pressure Testing Procedure	28-29
IOM - Installation and Maintenance Guidelines	30-32
Valves Assembling Set	33-34







## GATE VALVES

### Engineering Data

#### Equivalent DIN / ANSI Material Designation for Cast Valve Material

	DIN	N° Material	AISI / ASTM
Cast Iron	GG20 - EN JL 1030 - EN GJL 200	0.5020	A48 30B
	GG25 - EN JL 1040 - EN GJL 250	0.5020	A48 40B
Ductile Iron	GGG40 - EN JS 1030 - EN GJS 400-15	0.7040	60-40-18
	GGG40.3 - EN JS 1020 - EN GJS 400-18	0.7043	-
	GGG50 - EN JS 1050 - EN GJS 500-7	0.7050	65-45-12

#### Specifications of Carbon Steel, Stainless and Exotic Materials acc. ASTM Standards

Material	Specification
FORGED CARBON STEEL	ASTM 105
CAST CARBON STEEL	ASTM A216WCB
LOW TEMPERATURE CARBON STEEL(ALLOY)	ASTM A352 LCB ASTM A352 LCC
CARBON STEEL(ALLOY) CrMo	ASTM A217 WC6
LOW ALLOY CARBON STEEL	ASTM A487 Gr4N ASTM A487 Gr4C
STAINLESS STEEL. 410	ASTM A217 CA15
STAINLESS STEEL. 9%Cr	ASTM A217 CA12
STAINLESS STEEL. 13%Cr	ASTM A352 CAGNM
HASTELLOY® C276	ASTM A494 CWRMN
MONEL	ASTM A494 M35-2
BRONZE ALUMINIUM-NIKEL	ASTM B148 GrWC9
STAINLESS STEEL 316	ASTM A 182 F 316 A 351 CF8M
STAINLESS STEEL 316	ASTM A 182 F 316L A 351 CF3M
STAINLESS STEEL 347 (HIGH TEMPERATURE)	ASTM A 351 CF8C
STAINLESS STEEL 304	ASTM A 351 CF8
STAINLESS STEEL 304 L	ASTM A 351 CF3
STAINLESS STEEL 317	ASTM A 351 CG8M
ALLOY 625	ASTM A 494 CW6MC
AVESTA 254 5Mo®	ASTM A351 CK3M CaN
TITANIUM	ASTM B367 C2



# GATE VALVES

## Engineering Data

### New Harmonized European Face to Face Length Standards / Standardized Face to Face Lengths

The following tables provide the equivalent length specification standard in accordance with the European Harmonization

FACE TO FACE CONSTRUCTION LENGTH	EN	DIN	REF: For Valves
	DIN EN 558-1 LINE1	DIN 3202 F1	GLOBE,DIAPHRAGM, REGULATING
	DIN EN 558-1 LINE14	DIN 3202 F4	GATE, BALL
	DIN EN 558-1 LINE15	DIN 3202 F5	GATE,BALL

### Flanged Valve Construction Lengths

Size	EN-558-1 S1 (DIN 3202 F1)	EN-558-1 S14 (DIN 3202 F4)	EN-558-1 S15 (DIN 3202 F5)	EN-558-1 S7 (ANSI / BS 5156)	ASME B.16.10-150 Gate	ASME B.16.10 300 Gate	ASME B.16.10-150 Globe	ASME B.16.10-300 Globe
DN15	130	115	---	108	108	140	108	152
DN20	150	120	---	117	117	152	117	178
DN25	160	125	120	127	127	165	127	203
DN32	180	130	140	146	140	178	140	216
DN40	200	140	240	159	165	190	165	229
DN50	230	150	250	190	178	216	203	267
DN65	290	170	270	216	191	241	216	292
DN80	310	180	280	254	203	283	241	318
DN100	350	190	300	305	229	305	292	356
DN125	400	200	325	356	254	381	356	400
DN150	480	210	350	406	267	403	406	444
DN200	600	230	400	521	292	419	495	559
DN250	730	250	450	635	330	457	622	622
DN300	850	270	500	749	356	502	698	711
DN350	980	290	550	-	381	762	787	-
DN400	1100	310	600	-	406	838	914	-
DN500	1250	350	700	-	457	991	978	-
DN600	1450	390	800	-	508	1143	1295	-
DN700	1650	430	900	-	610	1346	1448	-
DN800	1850	470	1000	-	-	1524	-	-



## GATE VALVES

### Engineering Data

#### Dimensional Table for DIN Standard Flanges acc. to EN1092-1

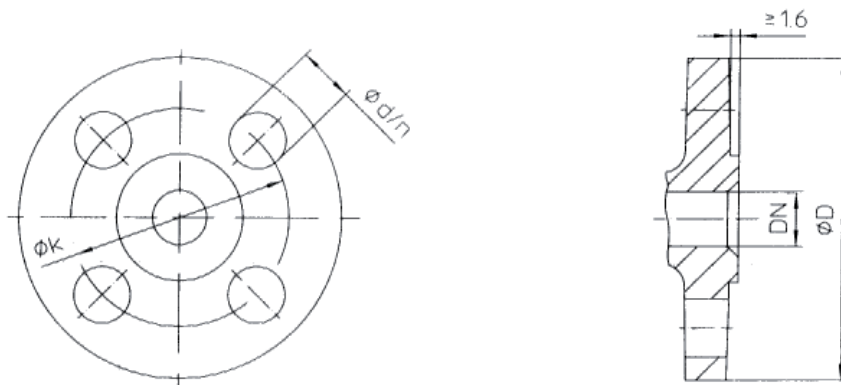

PN10						PN16			
DIN	Inchs	ØD	Øk	Ød	n	ØD	Øk	Ød	n
10	3/8"	90	60	14	4	90	60	14	4
15	1/2"	95	65	14	4	95	65	14	4
20	3/4"	105	75	14	4	105	75	14	4
25	1"	115	85	14	4	115	85	14	4
32	1 1/4"	140	100	18	4	140	100	18	4
40	1 1/2"	150	110	18	4	150	110	18	4
50	2"	165	125	18	4	165	125	18	4
65	2 1/2"	185	145	18	4	185	145	18	4
80	3"	200	160	18	4	200	160	18	4
100	4"	220	180	18	8	220	180	18	8
125	5"	250	210	18	8	250	210	18	8
150	6"	285	240	22	8	285	240	22	8
200	8"	340	295	22	8	340	295	22	12
250	10"	395	350	22	12	405	355	26	12
300	12"	445	400	22	12	460	410	26	12
350	14"	505	460	22	12	520	470	26	12
400	16"	565	515	26	16	580	525	30	16
500	20"	670	620	26	20	715	620	33	20

PN25						PN40			
DIN	Inchs	ØD	Øk	Ød	n	ØD	Øk	Ød	n
10	3/8"	90	60	14	4	90	60	14	4
15	1/2"	95	65	14	4	95	65	14	4
20	3/4"	105	75	14	4	105	75	14	4
25	1"	115	85	14	4	115	85	14	4
32	1 1/4"	140	100	18	4	140	100	18	4
40	1 1/2"	150	110	18	4	150	110	18	4
50	2"	165	125	18	4	165	125	18	4
65	2 1/2"	185	145	18	4	185	145	18	4
80	3"	200	160	18	4	200	160	18	4
100	4"	220	180	18	8	235	190	22	8
125	5"	250	210	18	8	270	220	26	8
150	6"	285	240	22	8	300	250	26	8
200	8"	360	310	26	12	375	320	30	12
250	10"	425	370	30	12	450	385	33	12
300	12"	485	430	30	16	515	450	33	12
350	14"	555	490	33	16	580	510	33	16
400	16"	620	550	36	16	660	585	36	16
500	20"	730	660	36	20	755	670	39	20



## GATE VALVES

### Engineering Data

#### Dimensional Table for ANSI Standard Flanges

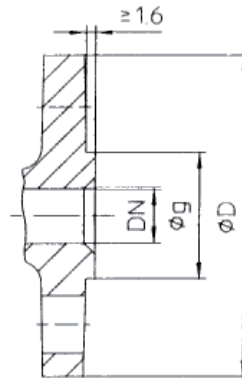
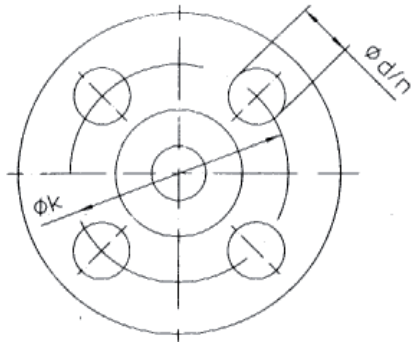

ANSI 150							ANSI 300				
DIN	Inchs	ØD	Øg	Øk	Ød	n	ØD	Øg	Øk	Ød	n
15	1/2"	89	35	60	16	4	95	35	67	16	4
20	3/4"	99	43	70	16	4	117	43	82,5	19	4
25	1"	108	51	79	16	4	124	51	89	19	4
32	1 1/4"	118	64	89	16	4	133	64	99	19	4
40	1 1/2"	127	73	98	16	4	156	73	114	22	4
50	2"	153	92	121	19	4	165	92	127	19	8
65	2 1/2"	178	105	140	19	4	191	105	149	22	8
80	3"	191	127	152	19	4	210	127	168	22	8
100	4"	229	157	191	19	8	254	157	200	22	8
125	5"	254	186	216	22	8	279	186	235	22	8
150	6"	279	216	241	22	8	318	216	270	22	12
200	8"	343	270	298	22	8	381	270	330	25	12
250	10"	406	324	362	25	12	445	324	387	29	16
300	12"	483	381	432	25	12	521	381	451	32	16
350	14"	533	413	476	29	12	584	413	514	32	20
400	16"	597	470	540	29	16	648	470	572	35	20
500	20"	699	584	635	32	20	775	584	686	35	24



## GATE VALVES

### Engineering Data

#### Dimensional Table for BS T, E, F, J, K Standard Flanges

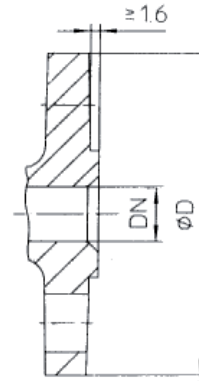
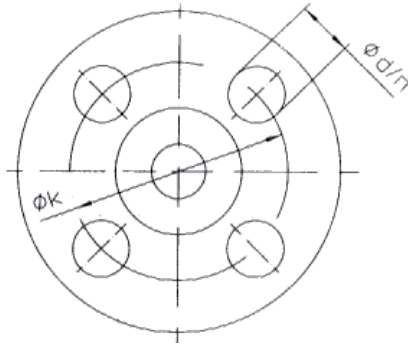

BS / E						BS / F			
DIN	Inchs	ØD	Øk	Ød	n	ØD	Øk	Ød	n
15	1/2"	95	67	14	4	95	67	14	4
20	3/4"	102	73	14	4	102	73	14	4
25	1"	114	83	14	4	121	87	18	4
32	1 1/4"	121	87	14	4	133	98	18	4
40	1 1/2"	133	98	14	4	140	105	18	4
50	2"	152	114	14	4	165	127	18	8
65	2 1/2"	165	127	18	4	184	146	18	8
80	3"	184	146	18	4	203	165	18	8
100	4"	216	178	18	8	229	191	18	8
125	5"	254	210	18	8	279	235	22	8
150	6"	279	235	22	8	305	260	22	12
200	8"	337	292	22	8	368	324	22	12

BS / J						BS / K			
DIN	Inchs	ØD	Øk	Ød	n	ØD	Øk	Ød	n
15	1/2"	114	83	18	4	114	83	18	4
20	3/4"	114	83	18	4	114	83	18	4
25	1"	121	87	18	4	127	95	18	4
32	1 1/4"	133	98	18	4	133	98	18	4
40	1 1/2"	140	105	18	4	152	114	22	4
50	2"	165	127	22	4	165	127	18	8
65	2 1/2"	184	146	22	8	184	146	22	8
80	3"	203	165	22	8	203	165	22	8
100	4"	229	191	22	8	241	197	25	8
125	5"	279	235	25	8	279	235	25	12
150	6"	305	260	25	12	305	260	25	12
200	8"	368	324	25	12	368	318	29	12



## GATE VALVES

### General Design Consideration



Gate Valves are devices to start or stop flow in a pipe system. They offer a straight-line flow of fluid with minimum flow restriction. In service, these valves generally work as On/Off, that is to say, either fully open or fully closed.

Gate Valves are featured by the movement of the stem guiding the closure element downwards to get the valve closed and upwards to get it open. The closing and opening actions are featured by a slow movement and usually governed either by a multi turn handwheel or any other manual device or by a multi turn actuator.

The closure element of a Gate Valve is called wedge or disc and it is completely removed from the valve passage when the valve is fully open; the wedge is fully drawn up into the valve bonnet. This leaves an opening for flow through the valve at the same inside diameter as the pipe system in which the valve is installed. A gate valve can be used for a wide range of liquids and provides a tight seal when closed.

Gate Valves consists of three main parts: body, bonnet, and trim. The body is generally connected to pipe system by means of flanged, screwed or welded connections. The bonnet, which containing the moving parts, is attached to the body, usually with bolts, to permit maintenance. The valve trim consists of the stem, the gate, the wedge or disc and the seat rings.

Resilient seat valves have normally integral seat area with the body, having a rubber coated wedge that directly contacts the valve body.

Gate Valves are available with different wedges or discs, being the most common ones:

- Solid wedge is the most commonly used disk by its simplicity and strength.

A valve with this type of wedge can be installed in each position and it is suitable for almost all liquids. The solid wedge is a single-piece solid construction, and is practically for turbulent flow.

- Flexible wedge is a one-piece disc with a cut around the perimeter to improve the ability to correct mistakes or changes in the angle between the seats. The reduction will vary in size, shape and depth. A shallow, narrow cut gives little flexibility but retains strength.

A deeper and wider cut, or cast-in recess, leaves little material in the middle, which allows more flexibility, but compromises strength.

- Split wedge is self-adjusting and self-aligning to both seats sides. This wedge type consists of two-piece construction which seats between the tapered seats in the valve body. This type of wedge is suitable for the treatment of non-condensing gases and liquids at normal temperatures, particularly corrosive liquids.



## GATE VALVES

### General Design Consideration

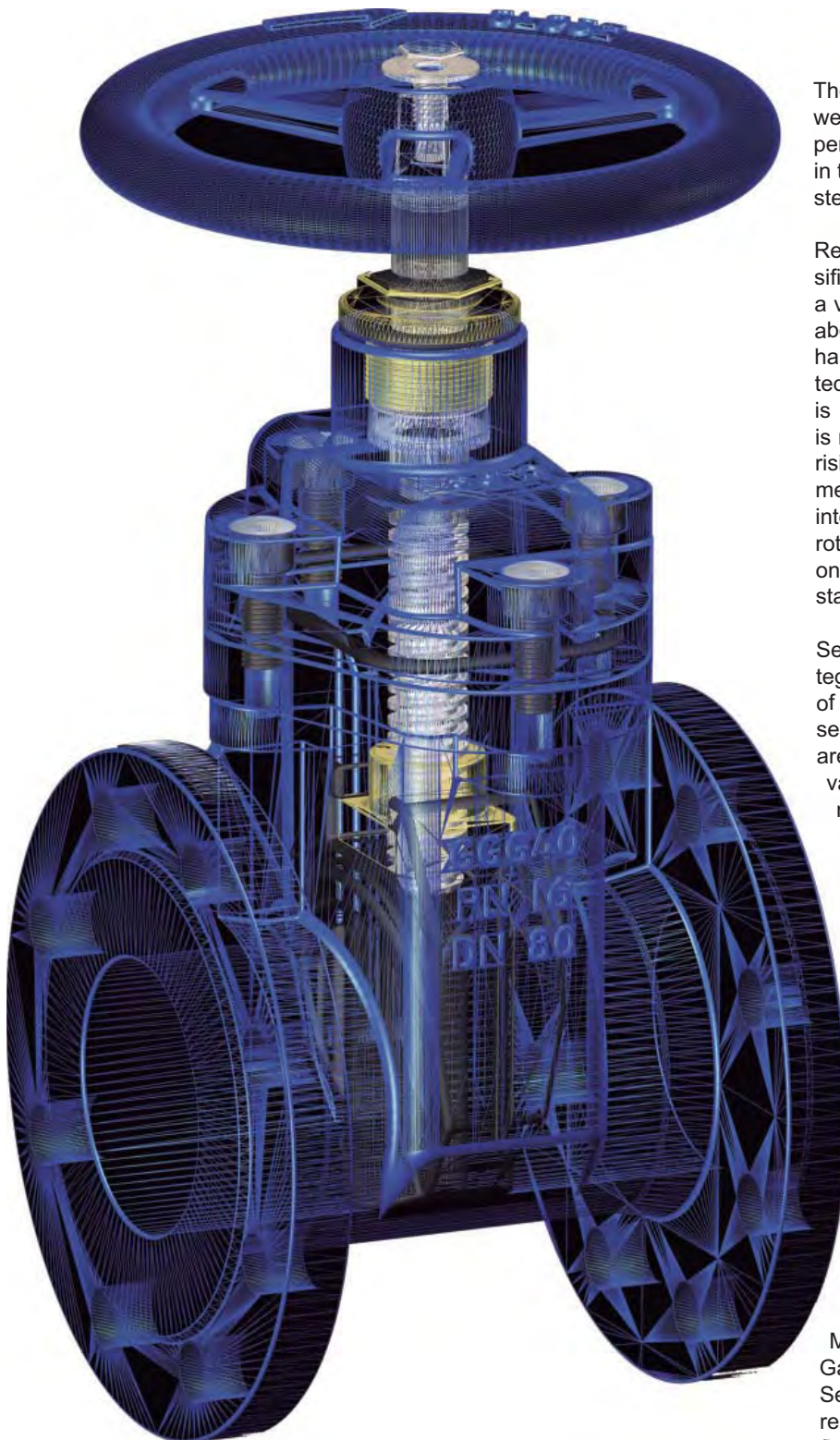

The stem, which connects the handwheel and wedge with each other, is responsible for the proper positioning of the wedge. To prevent leakage, in the area of the seal, a fine surface finish of the stem is necessary.

Regarding the stem motion, Gate Valves are classified as either rising stem or non rising stem. For a valve of the rising stem type, the stem will rise above the handwheel if the valve is opened. This happens, because the stem is threaded and mated with the bushing threads of a yoke. A yoke is an integral part from a rising stem valve and is mounted to the bonnet. For a valve of the non rising stem type, there is no upward stem movement if the valve is opened. The stem is threaded into the wedge. As the handwheel on the stem is rotated, the wedge travels up or down the stem on the threads while the stem remains vertically stationary.

Seats for Gate Valves are either provided integral with the valve body or in a seat ring type of construction. Seat ring construction provides seats which are either threaded into position or are pressed into position and seal welded to the valve body. The latter form of construction is recommended for higher temperature service. Integral seats provide a seat of the same material of construction as the valve body while the pressed-in or threaded-in seats permit variation. Rings with hard facings may be supplied for the application where they are required.

The main advantages of using Gate Valves is a good closing performance, they are bidirectional (they can be used in two directions) and they offer a large capacity (minimal pressure loss across the valve). The mayor drawbacks are the slow operation (sometimes and advantage to prevent water hammers), and they are not suitable for throttling duties, with non-regulating characteristic and problems of vibrations.

This Data Sheets Manual is comprehensive of the two main manufacturing lines of the COMEVAL range of Gate Valves: Resilient Seated Gate Valves (Series 504-505-507) and Metal Seated Gate Valves (Series 31-32-33) in pressure rating PN 10-16-25-40 for a wide application field of Water Works, Irrigation, Fire Fighting Systems and Process



## GATE VALVES

### Flow Data

A valve flow coefficient represents the standard flow rate which flows through the valve at a given opening, referred to pre-established conditions:

\* Kv value is the volume of water at 20°C, in cubic meters per hour (m<sup>3</sup>/h), that will flow through the valve at a static pressure drop of 1 bar across the valve

\* Cv value is the volume of water at 60°F, in gallons per minute (gpm), that will flow through the valve at a static pressure drop of 1 psi across the valve

Conversion from Kv to Cv can be roughly calculated by means of the following expression:

$$Cv = Kv \times 1,17$$

Flow rate through the valve with other liquids can be calculated with the following expressions (*for gases please consult us*)

$$Kv = q (SG / dp)^{1/2}$$

where

*q = water flow (m<sup>3</sup>/h)*

*SG = specific gravity (1 for water)*

*dp = pressure drop (bar)*

$$Cv = q (SG / dp)^{1/2}$$

where

*q = water flow (US gallons per minute)*

*SG = specific gravity (1 for water)*

*dp = pressure drop (psi)*

It is common practice to size the Gate Valves on the basis of pipe DN for on off application.

As a general guideline, flow velocities should be under certain limits, so as to avoid valve excessive noise, vibration and cavitation:

some valves for reference: Liquids < 4,5 m/s; Gases < 100 m/s

COMEVAL Technical Department is at your disposal to help you sizing your system.

#### Typical Kv valves for Gate Valves

DN (mm)	40	50	65	80	100	125	150	200	250	300	400	500
Kv(m <sup>3</sup> /h)	140	220	370	560	880	1380	2300	4090	6390	9200	16350	25560



## GATE VALVES

### Soft Seat Gate Valve- Series 504/505

#### Attributes of Design

Non-rising hand-wheel, Non-rising inner screw spindle. Smooth Operation.  
Other actuation possibilities such as square key, extended spindle for underground duties, electric actuation

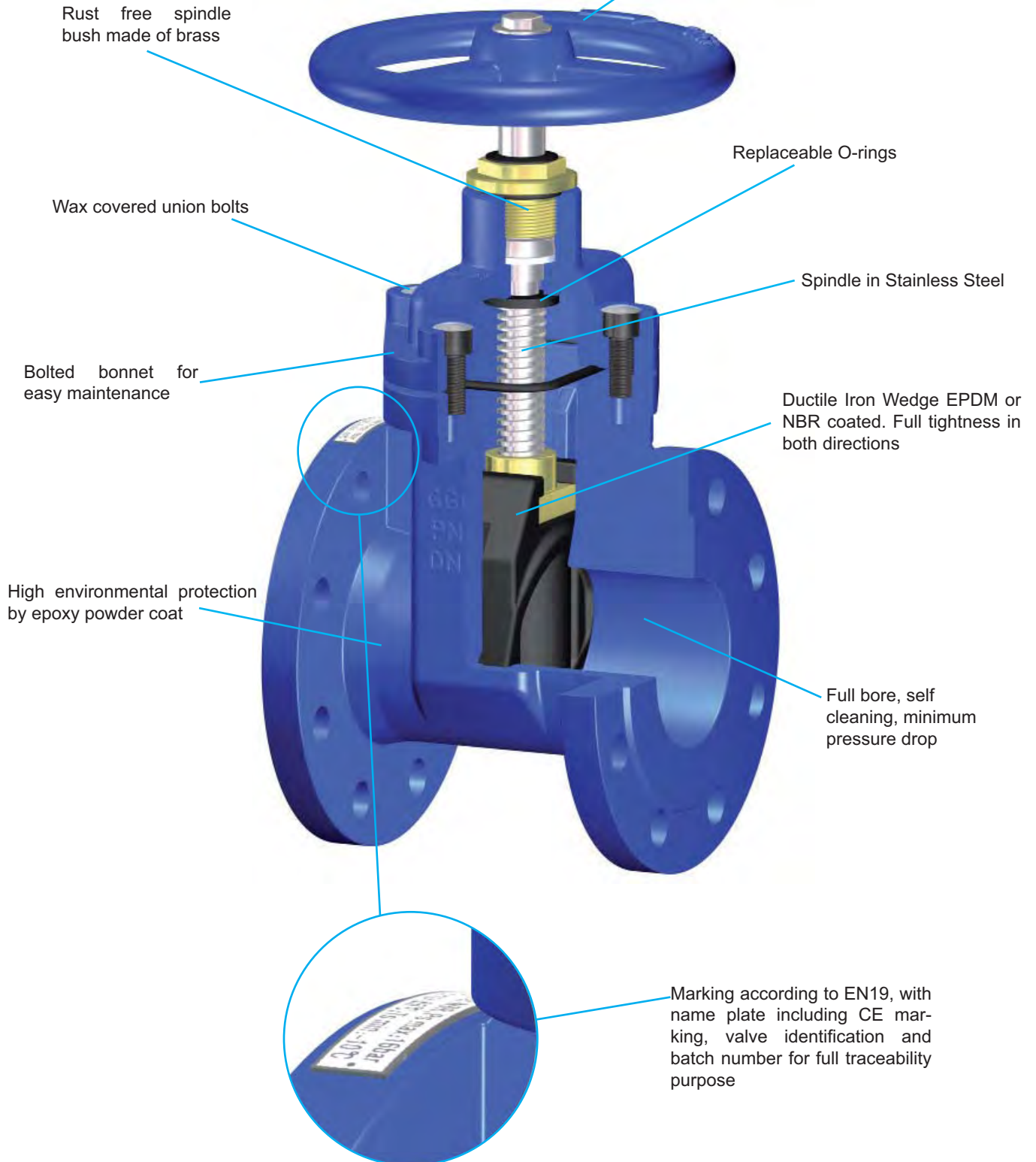



## GATE VALVES

### Soft Seat Gate Valve- Series 504/505 Parts and Materials

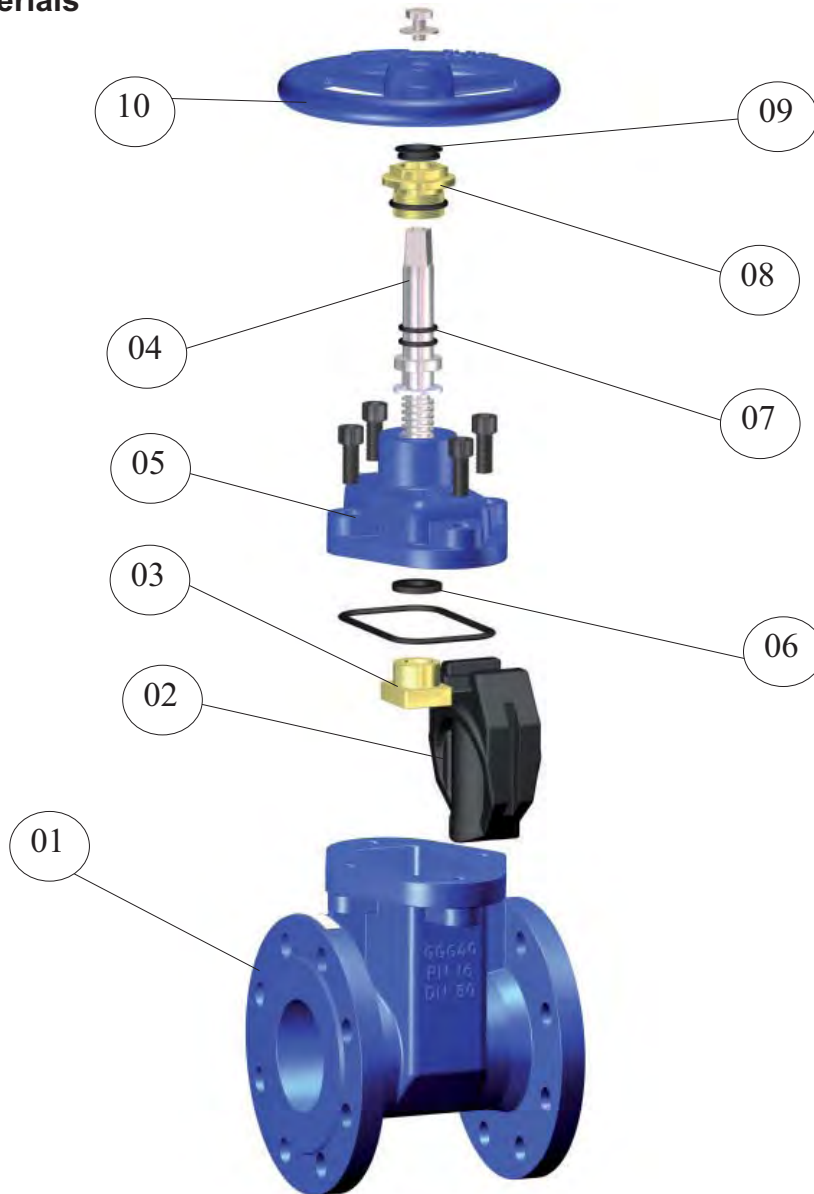

N°	Part	Material
1	BODY	Ductil iron EN-JS1050 (GGG50)
2	WEDGE	Ductil Iron GGG50 Coated: NBR or EPDM
3	BACK SEAT	Brass 38-2-2
4	SPINDLE	St. Steel 410
5	BONNET	Ductile Iron EN-JS1050 (GGG50)
6	PACKING SPINDLE	NBR or EPDM
7	O-RINGS	NBR or EPDM
8	GLAND BUSHING	BRASS 38-2-2
9	BUSH SEALS	NBR or EPDM
10	HANDWHEEL	Ductile Iron EN-JS1050 (GGG50)



## GATE VALVES

### Soft Seat Gate Valve 504 PN16

#### Dimensions,

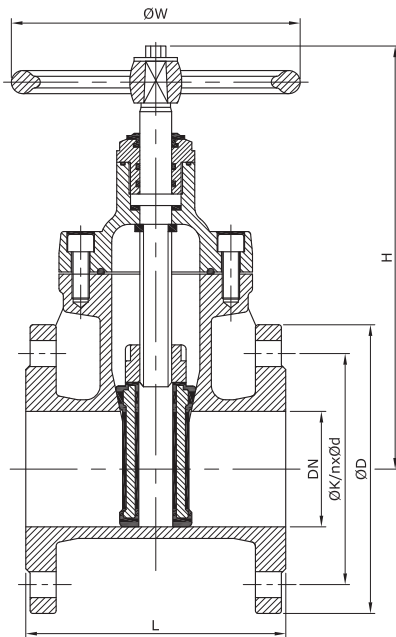

DN	40	50	65	80	100	125	150	200	250	300	350	400	450	500	600	700	800
L	140	150	170	180	190	200	210	230	250	270	290	310	330	350	390	430	470
H	260	270	283	311	352	435	485	520	632	745	835	953	1120	1320	1445	1545	1750
ØW	160	180	180	200	250	280	320	350	400	500	600	600	600	700	700	900	900
ØD	150	165	185	200	220	250	285	340	405	460	520	580	640	715	840	910	1025
ØK	110	125	145	160	180	210	240	295	355	410	470	525	585	650	770	840	950
nxØd	4x19	4x19	4x19	8x19	8x19	8x19	8x23	12x23	12x28	12x28	16x28	16x31	20x31	20x34	20x37	24x37	24x40

#### Manufacturing Design Standards:

Harmonized Standards: EN 1171, DIN3352, BS5163

QA certified to ISO 9001:2000

According to Pressure Equipment Directive 97/23/CE

Testing Standards: EN12266-1, DIN3230

Standard Clockwise to close (Option Anti-Clockwise to close)

Face to face length to EN558-S14 (DIN3202 F4). EN558-S15 (DIN3202 F5) on request

Body end connections: flanged to EN1092-2

Marking to EN19

Epoxy paint blue similar to RAL5005, min. 150 µm

ANSI construction and further options on request

#### Operating Parameters:

Working pressure: 0...16 bar-g

Working temperature: NBR -10...80°C; EPDM -10...120°C

Shell strength and tightness test EN12266-1 P10/P11 1,5xPs

Seat tightness test EN12266-1 P12 1,1xPs – Rate A, no visually detectable leakage for the duration of the test

See Engineering Data for complete overview of operating parameters

#### Main Applications:

HVAC, Water distribution, Water Treatment Plants, Irrigation Systems



## GATE VALVES

### Soft Seat Gate Valve 504 PN25 Dimensions

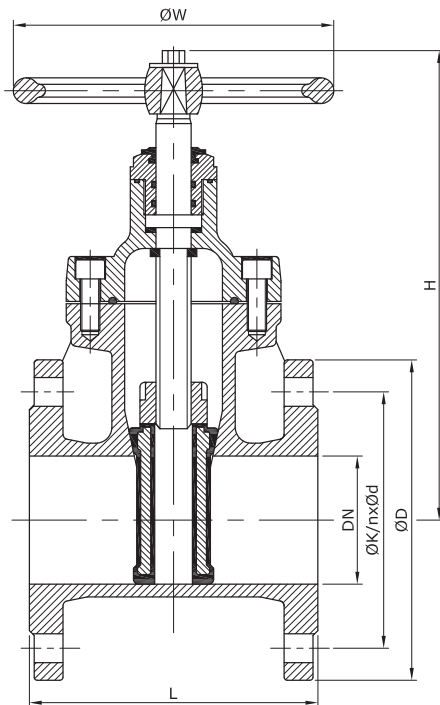

DN	40	50	65	80	100	125	150	200	250	300	350
L	140	150	170	180	190	200	210	230	250	270	290
H	260	270	283	311	352	435	485	520	632	745	900
ØW	160	180	180	200	250	280	320	350	400	500	600
ØD	150	165	185	200	235	270	300	360	425	485	555
ØK	110	125	145	160	190	220	250	310	370	430	490
nxØd	4x19	4x19	8x19	8x19	8x23	8x28	8x28	12x28	12x31	16x31	16x34

#### Manufacturing Design Standards:

Harmonized Standards: EN 1171, DIN3352, BS5163

QA certified to ISO 9001:2000

According to Pressure Equipment Directive 97/23/CE

Testing Standards: EN12266-1, DIN3230

Standard Clockwise to close (Option Anti-Clockwise to close)

Face to face length to EN558-S14 (DIN3202 F4). EN558-S15 (DIN3202 F5) on request

Body end connections: flanged to EN1092-2

Marking to EN19

Epoxy paint blue similar to RAL5005, min. 150 µm

ANSI construction and further options on request

#### Operating Parameters:

Working pressure: 0...25 bar-g

Working temperature: NBR -10...80°C; EPDM -10...120°C

Shell strength and tightness test EN12266-1 P10/P11 1,5xPs

Seat tightness test EN12266-1 P12 1,1xPs – Rate A, no visually detectable leakage for the duration of the test

See Engineering Data for complete overview of operating parameters

#### Main Applications:

HVAC, Water distribution, Water Treatment Plants, Irrigation Systems



## GATE VALVES

### Soft Seat Gate Valve 505 PN10

#### Dimensions

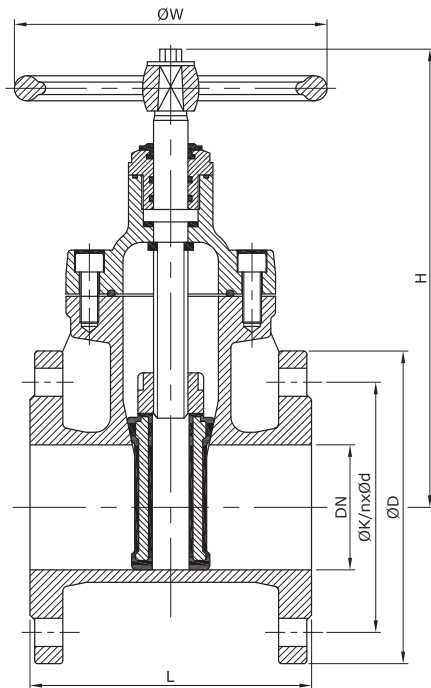

DN	40	50	65	80	100	125	150	200	250	300	350	400
L	140	150	170	180	190	200	210	230	250	270	290	310
H	260	270	283	311	352	435	485	520	632	745	835	953
ØW	160	180	180	200	250	280	320	350	400	450	500	550
ØD	150	165	185	200	220	250	285	340	395	445	505	565
ØK	110	125	145	160	180	210	240	295	350	400	460	515
nxØd	4x18	4x18	4x18	8x18	8x18	8x18	8x22	8x22	12x22	12x22	16x22	16x26

#### Manufacturing Design Standards:

Harmonized Standards: EN 1171, DIN3352, BS5163

QA certified to ISO 9001:2000

According to Pressure Equipment Directive 97/23/CE

Testing Standards: EN12266-1, DIN3230

Standard Clockwise to close (Option Anti-Clockwise to close)

Face to face length to EN558-S14 (DIN3202 F4). EN558-S15 (DIN3202 F5) on request

Body end connections: flanged to EN1092-2

Marking to EN19

Epoxy paint blue similar to RAL5005, min. 150 µm

ANSI construction and further options on request

#### Operating Parameters:

Working pressure: 0...10 bar-g

Working temperature: NBR -10...80°C; EPDM -10...120°C

Shell strength and tightness test EN12266-1 P10/P11 1,5xPs

Seat tightness test EN12266-1 P12 1,1xPs – Rate A, no visually detectable leakage for the duration of the test

See Engineering Data for complete overview of operating parameters

#### Main Applications:

HVAC, Water distribution, Water Treatment Plants, Irrigation Systems



## GATE VALVES

### Soft Seat Gate Valve – Series 507

#### Attributes of Design

Non-rising hand-wheel, Rising spindle.  
Smooth Operation.  
Visual indication other actuation possibilities  
such as square key, extended spindle for  
underground duties, electric actuation

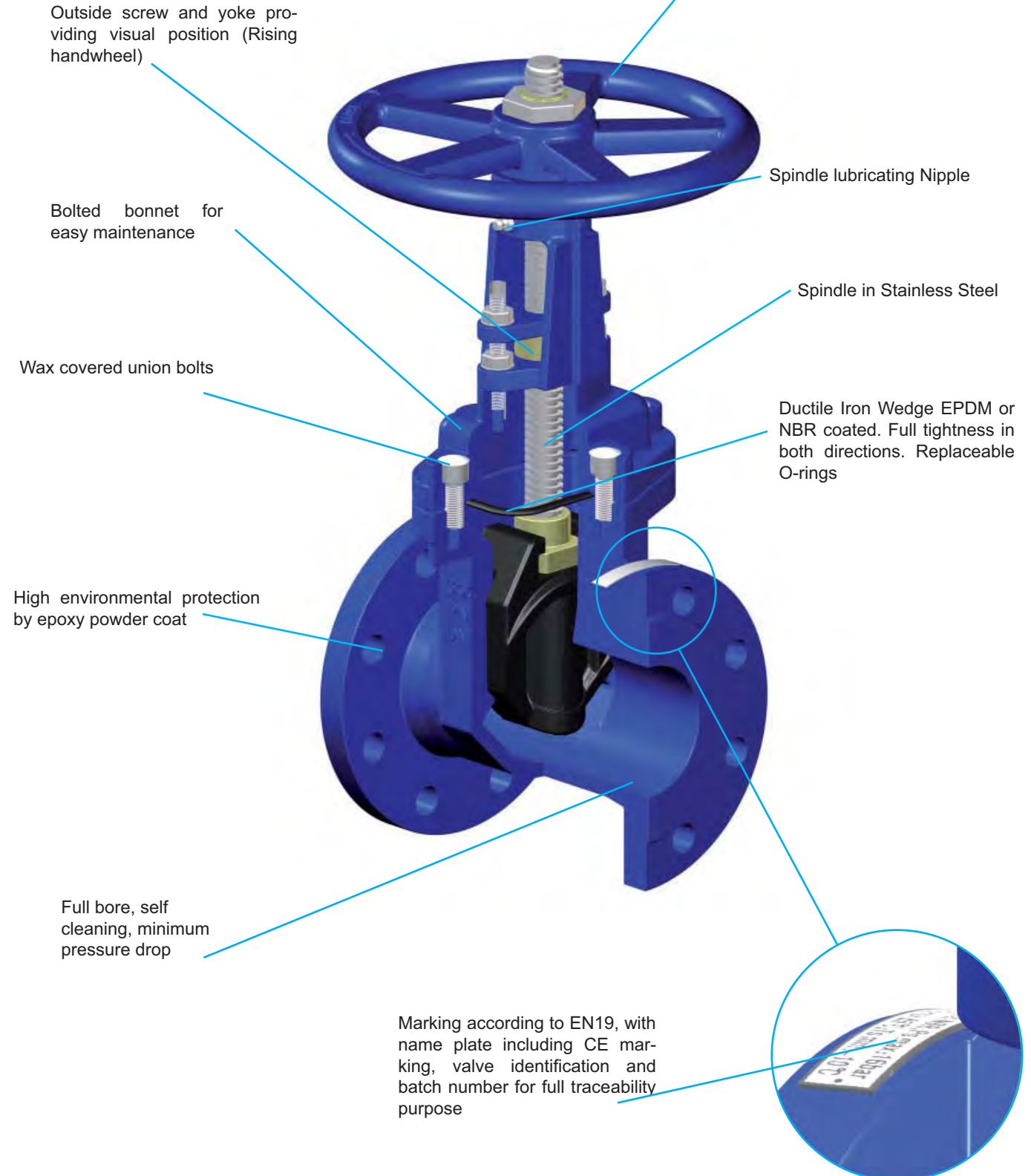

Outside screw and yoke providing visual position (Rising handwheel)

Bolted bonnet for easy maintenance

Wax covered union bolts

High environmental protection by epoxy powder coat

Full bore, self cleaning, minimum pressure drop

Spindle lubricating Nipple

Spindle in Stainless Steel

Ductile Iron Wedge EPDM or NBR coated. Full tightness in both directions. Replaceable O-rings

Marking according to EN19, with name plate including CE marking, valve identification and batch number for full traceability purpose



## GATE VALVES

### Soft seat Gate Valve- Serie 507

#### Parts and Materials

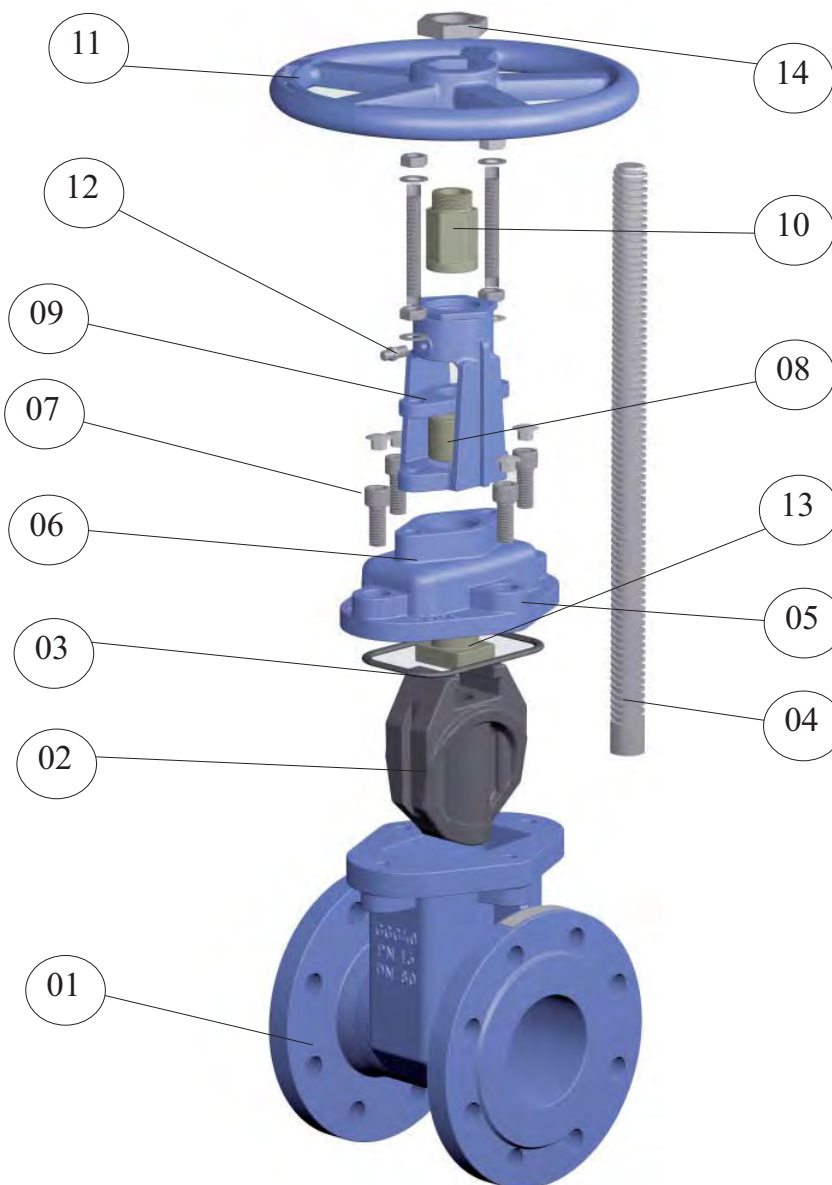

N°	Part	Material
1	BODY	Ductil iron EN-JS1050 (GGG50)
2	WEDGE	Ductil Iron GGG50 Coated: NBR or EPDM
3	BACK SEAT	Brass 38-2-2
4	SPINDLE	St. Steel 410
5	GASKET	NBR or EPDM
6	BONNET	Ductile Iron EN-JS1050 (GGG50)
7	BOLT/NUT	A 194 2H/ A 193 B7
8	GLAND	Ductile Iron EN-JS1050 (GGG50)
9	YOKE	Ductile Iron EN-JS1050 (GGG50)
10	STEM NUT/ RETAIN NUT	St. Steel 410
11	HANDWHEEL	Ductil Iron EN-JS1050 (GGG50)
12	GREASING NIPPLE	St. Steel 410
13	COVER BOLT	Wax
14	NUT	Carbo Steel



## GATE VALVES

### Soft Seat Gate Valve 507 PN16 Dimensions

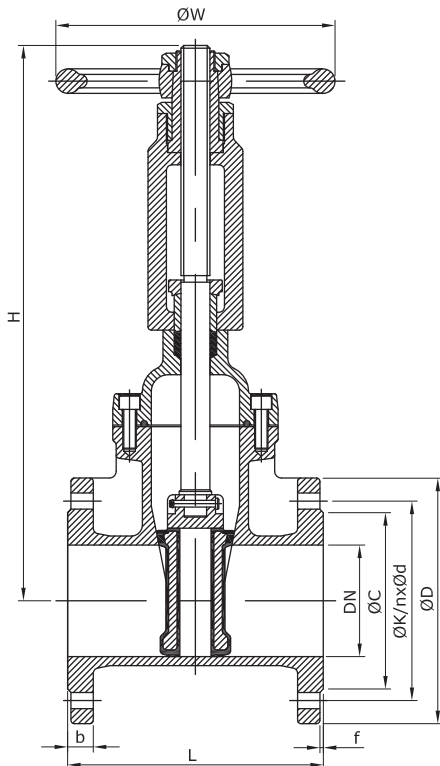

DN	50	65	80	100	125	150	200	250	300	350	400	450	500	600	700
L	150	170	180	190	200	210	230	250	270	290	310	330	350	390	430
H (open)	405	44	465	510	580	645	745	975	1165	1540	1760	2025	2335	2755	3055
ØW	180	180	200	250	250	300	350	400	500	500	600	600	750	750	960
ØD	165	185	200	220	250	285	340	405	460	520	580	640	715	840	910
ØK	125	145	160	180	210	240	295	355	410	470	525	585	650	770	840
nxØd	4x19	4x19	8x19	8x19	8x19	8x23	12x23	12x28	12x28	16x28	16x31	20x31	20x34	20x37	24x37
f	3	3	3	3	3	3	3	3	3	4	4	4	4	5	5
b	19	19	19	19	19	20	22	25	27	27	28	30	32	36	38

#### Manufacturing Design Standards:

Harmonized Standards: EN 1171, DIN3352, BS5163

QA certified to ISO 9001:2000

According to Pressure Equipment Directive 97/23/CE

Testing Standards: EN12266-1, DIN3230

Standard Clockwise to close (Option Anti-Clockwise to close)

Face to face length to EN558-S14 (DIN3202 F4). EN558-S15 (DIN3202 F5) on request

Body end connections: flanged to EN1092-2

Marking to EN19

Epoxy paint blue similar to RAL5005, min. 150 µm

ANSI construction and further options on request

#### Operating Parameters:

Working pressure: 0...16 bar-g

Working temperature: NBR -10...80°C; EPDM -10...120°C

Shell strength and tightness test EN12266-1 P10/P11 1,5xPs

Seat tightness test EN12266-1 P12 1,1xPs – Rate A, no visually detectable leakage for the duration of the test

See Engineering Data for complete overview of operating parameters

#### Main Applications:

HVAC, Water distribution, Water Treatment Plants, Irrigation Systems, Fire Fighting Systems



# GATE VALVES

## Soft Seat Gate Valve

### Working Parameters

#### Seats - Application Guide 504/505/507

##### **NBR Butadiene Acrylonitrile** (-20°C) -10°C ... 70°C (80°C)

Lubricating oil, cutting oils, fuel oils, animal and vegetable oils, aviation kerosen, LPG, oily air. Generally resistant to oils and solvents.

Limited resistance to ozone and wheather.

##### **EPDM Ethylene Propylene Diene** (-20°C) -5°C ... 110°C (120°C)

Salts in water, diluted acids, alkaline solutions, ester, ketones, alcohols, glycols, hot water, intermittent steam, sterilisation  
Good resistance to ozone and wheather.

It is attacked by hydrocarbon solutions, chlorinated hydrocarbons and other petroleum based oils.

#### Temperature chart EPDM/NBR for neutral liquids

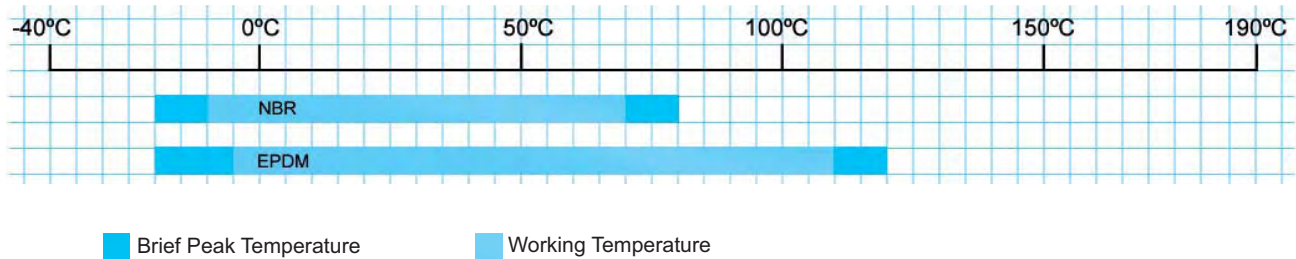

Temperature ranges given just for reference.

Body pressure-temperature rating also to be considered for valve selection.

Please consult our Technical Department for a particular application.

#### Pressure-Temperature Rating for neutral liquids 504/505/507

##### Valve Bodies and Bonnets

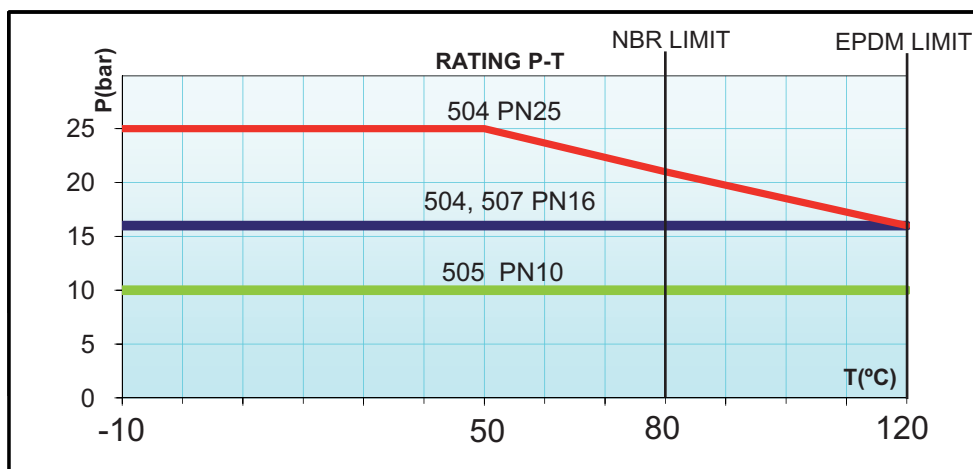



## GATE VALVES

### Soft Seat Gate Valve- Series 504/505/507 Closing torque and number of turns

Maximum recommended closing torque values (Nm)		Number of turns for full valve stroke	
DN40	50	DN40	10.5
DN50	60	DN50	13
DN65	75	DN65	17
DN80	75	DN80	16.5
DN100	100	DN100	20.5
DN125	125	DN125	25.5
DN150	150	DN150	30.5
DN200	200	DN200	34
DN250	250	DN250	42.5
DN300	300	DN300	50.5
DN350	325	DN350	44.5
DN400	350	DN400	50.5
DN450	425	DN450	57
DN500	525	DN500	63.5
DN600	800	DN600	60.5
DN700	850	DN700	73
DN800	950	DN800	69



## GATE VALVES

### Metal Seat Gate Valve– Series 31/32/33

#### Attributes of Design

Non-rising hand-wheel, And visual operation.  
Smooth Operation.  
Other actuation possibilities such as square key, extended spindle for underground duties, electric actuation

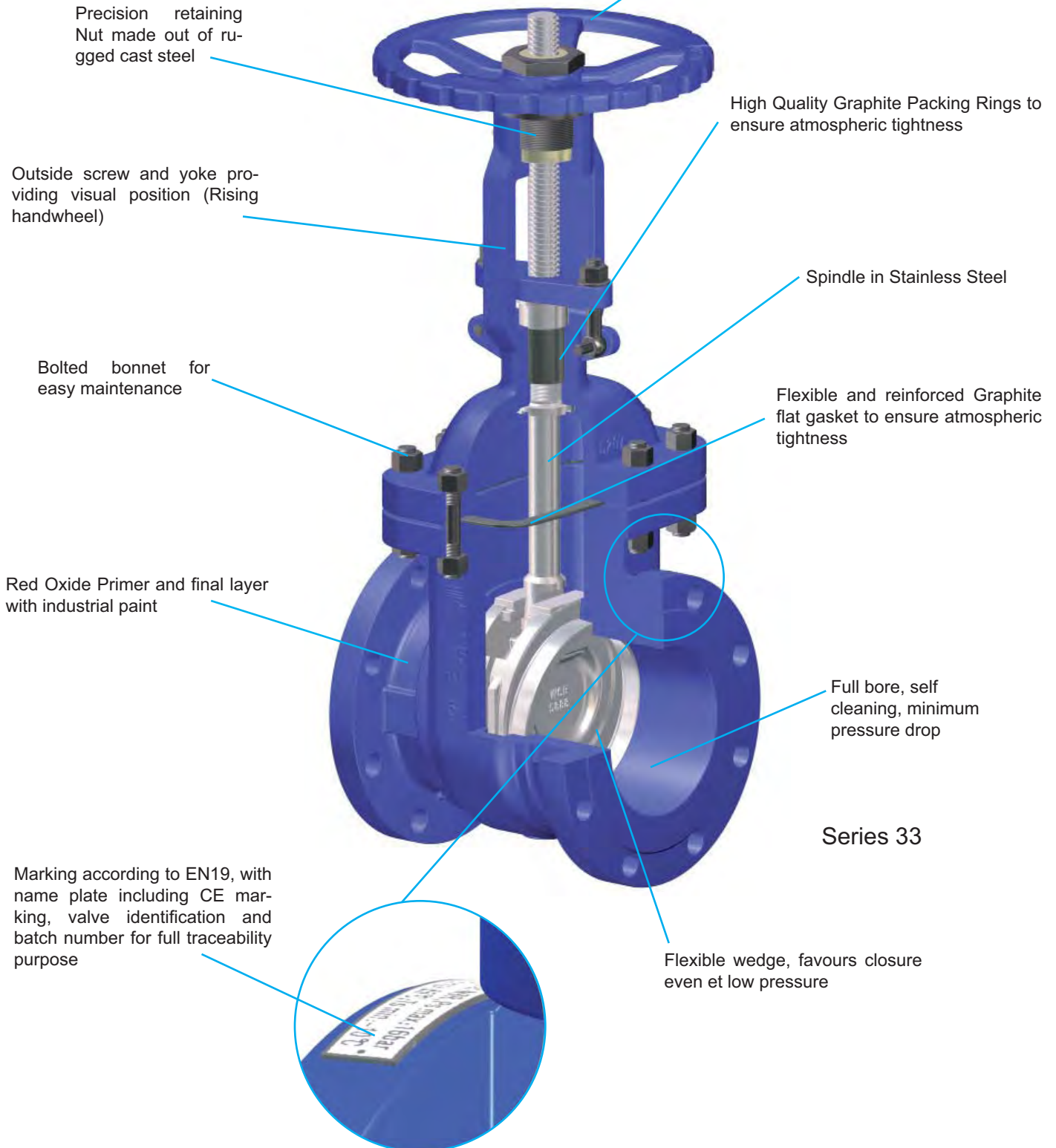



## GATE VALVES

### Metal Seat Gate Valve– Series 31/32/33

#### Parts and Materials

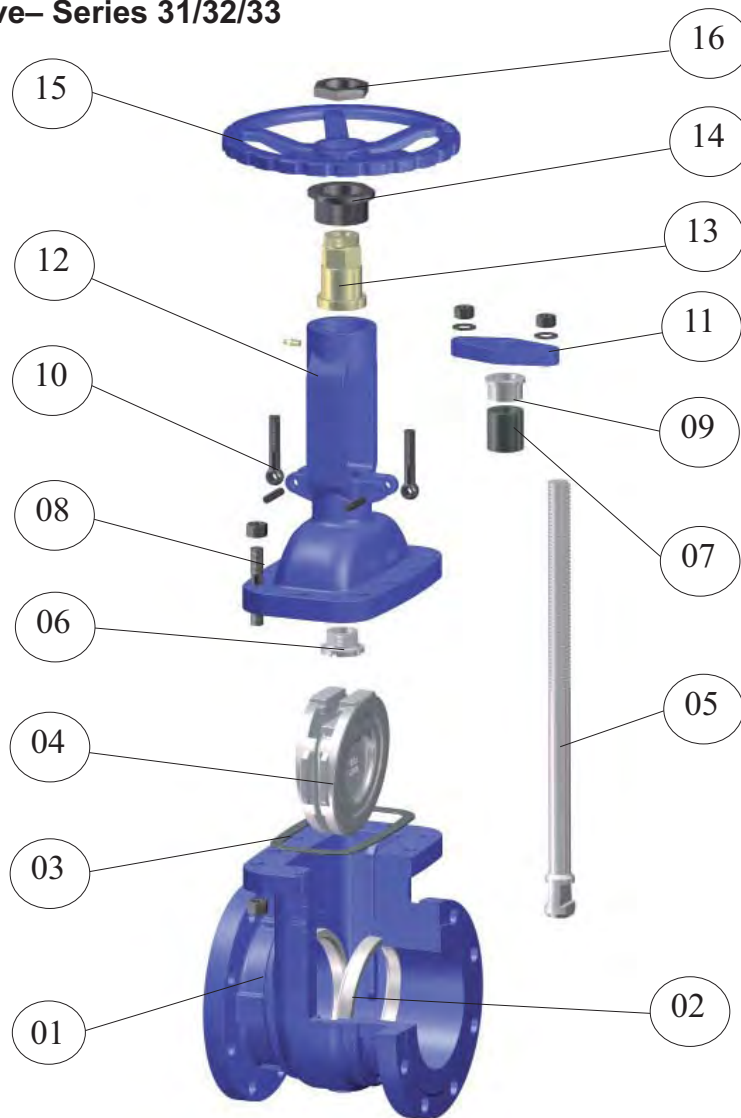

Nº	Part	Material
1	BODY	Cast Iron EN-JL1040 ; Cast Steel EN-1.0619; St. Steel EN-1.4408
2	SEAT	BrASS ST. Steel EN 1.4408
3	GASKET	Graphite
4	WEDGE	Cast Iron+ Bronze; Carbone Steel 13Cr
5	STEM	Brass or St. Steel 410
6	RETAIN NUT	Carbon Steel
7	PACKING	Graphite
8	BOLT/NUT	A194 2H/ A193 B7
9	RETAINING NUT	Carbon Steel
10	GLAND EYEBOLT	A193 B7
11	GLAND	GS-C25
12	BONNET	Cast Iron EN-JL1040; Cast Steel EN-1.0619; St Steel EN-1.4408
13	STEM NUT	A439 D2
14	RETAINING NUT	Carbon Steel
15	HANDWHEEL	Cast Iron; Ductil Iron
16	NUT	Carbon Steel



## GATE VALVES

### Metal Seat Gate Valve- Metal Seated Gate Valve series 31/32/33

#### Dimensions

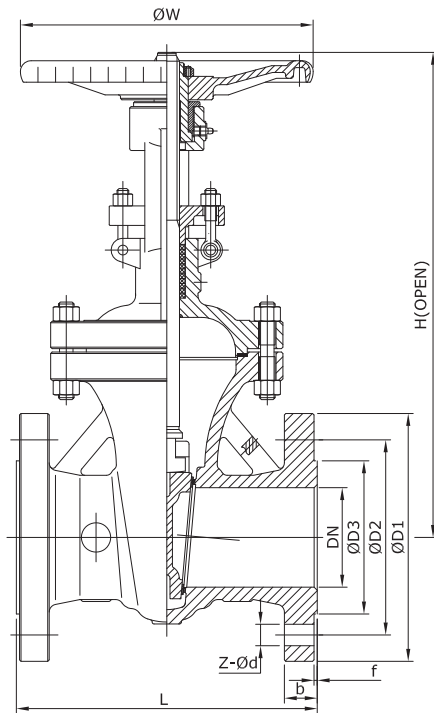

DN	50	65	80	100	125	150	200	250	300	350	400	500	600
L (S31)	150	170	180	190	200	210	230	250	270	290	-	-	-
L (S33 PN16/25)	250	270	280	300	325	350	400	450	500	550	600	700	800
L (S33 PN40)	250	290	310	350	400	450	550	650	750	850	950	1150	1350
H (S31)	280	293	342	380	445	490	605	672	870	934	-	-	-
H (S33)	380	470	550	670	725	880	1085	1300	1540	680	1900	2580	2920
nxØd (PN10)	4xØ18	4xØ18	4xØ18	8xØ18	8xØ18	8xØ23	8xØ23	12xØ23	12xØ23	12xØ23	-	-	-
D1 (PN10)	102	122	138	158	188	212	268	320	370	430	-	-	-
nxØd (PN16)	4xØ18	4xØ18	8xØ18	8xØ18	8xØ18	8xØ22	12xØ22	12xØ26	12xØ26	16xØ26	16xØ30	20xØ33	20xØ36
D1 (PN16)	165	185	200	220	250	285	340	405	460	520	580	715	840
nxØd (PN25)	4xØ18	8xØ18	8xØ18	8xØ22	8xØ26	8xØ26	12xØ26	12xØ30	16xØ30	16xØ33	16xØ36	20xØ36	20xØ39
D1 (PN25)	165	185	200	235	270	300	360	425	485	555	620	730	845
nxØd (PN40)	4xØ18	8xØ18	8xØ18	8xØ22	8xØ26	8xØ26	12xØ30	12xØ33	16xØ33	16xØ36	16xØ39	20xØ42	20xØ48
D1 (PN40)	165	185	200	235	270	300	375	450	515	580	660	755	890

#### Manufacturing Design Standards:

Harmonized Standards: EN 1171 (1984), DIN 3352 Sec. 4, BS5163

QA certified to ISO 9001:2000

According to Pressure Equipment Directive 97/23/CE

Testing Standards: EN-12266-1, DIN 3230-3

Standard Clockwise to close (Optionally anti-clockwise to close)

Face to Face length to EN-558-S15

Body end connections: flanged to EN 1092/1

Marking: EN 19

#### Operating Parametres:

Working Pressure: 0...40 barg (max. S33)

Working temperature: -10°C ... 450°C (Observe P/T relationship).

Shell strength and tightness test: EN 12266-1 P10/11 – 1.5XPs

Seat Tightness Test: EN-12266-1 P12 – 1.1 x Ps – Rate B – Permissible water drops per minute as per the standard (for more accurate parametres check out with COMEVAL technical Department).

#### Main Applications:

Process, Low Pressure Steam, High pressure cold water, Fire Fighting systems, Ballast and deck valves, Marine duties, desalination plants (stainless steel).



# GATE VALVES

## Metal Seat Gate Valve- Series 31/32/33

### Working Parameters

#### Pressure-Temperature Rating for neutral liquids S31/S32/S33

PN 25 / PN 40 ●●●●●●●●●● **GS-C25 N**  
up to 400°C  
PN 16 ————— **GG-25**  
up to 300°C

(1) Sección gráfica. Válvulas con cierre metal/metal, construcción DIN para ratings de presión PN6-40. Materiales constructivos hierro fundido GG25, GSC25N y acero inox. fundido 1.4408.  
(1) Graphic section. Valve metal/metal sealing, construction DIN for pressure ratings PN6-40. Cast iron construction material GG25, spheroidal casting GGG40.3, carbon steel GSC25N and stainless steel casting 1.4408.

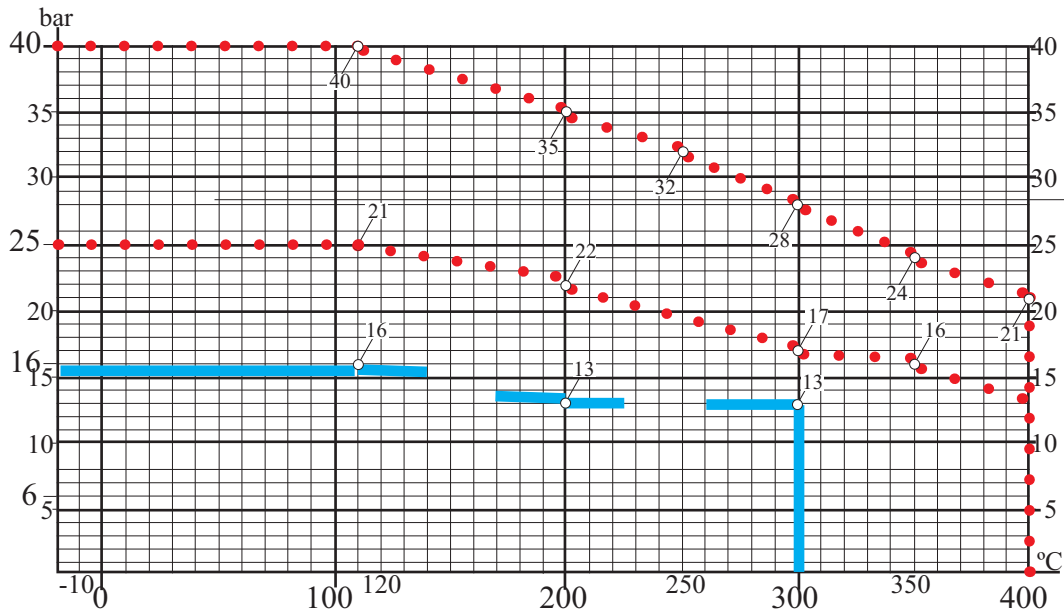

PN 40 ●●●●●●●●●● Acero Inox. / Stainless steel G-X6 Cr Ni Mo 1810  
PN 25 - - - - - Rango Temperatura / Temp. range. -60°C up to +400°C  
PN 16 —————

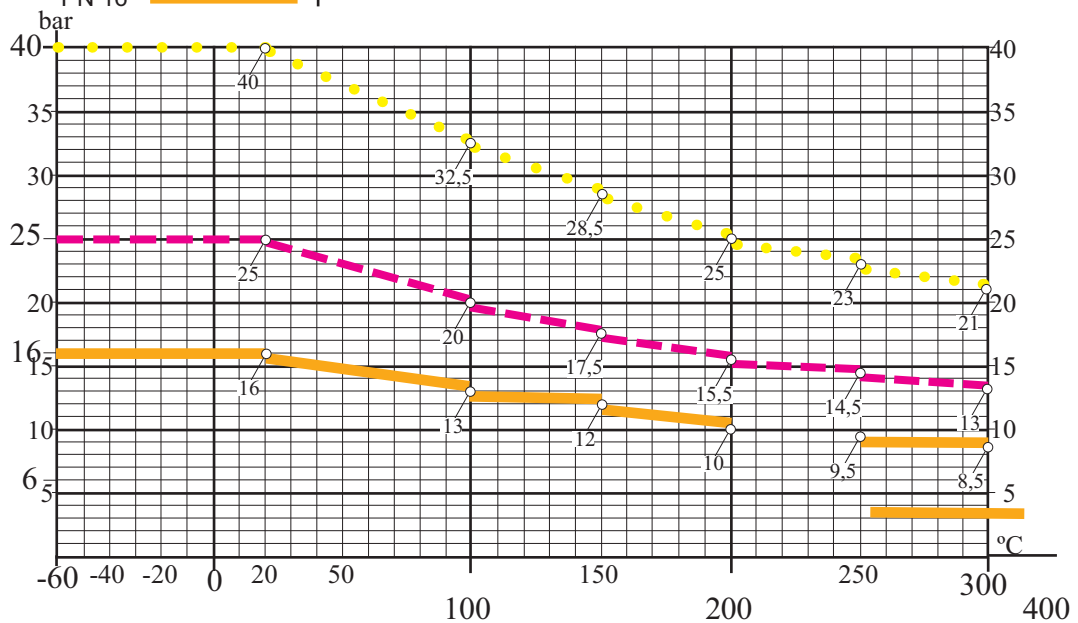



# GATE VALVES

## Actuation and Accesories

COMEVAL Gate Valves can be provided with a wide range of solutions on actuation and control accessories which is all packaged at our works according to customer specifications. The modular system permits to distributors and plant users to assemble or replace the diverse options in site. Virtually most applications that may be encountered on the industry today are covered with the standard range of actuation and accessories, nevertheless, other customer tailored solutions can be provided by our R&D Section.

**Handwheel**



**Electric Actuator**



**Squares**



**Gear box**



**Level wrench**



**Limit switches**



**Simple extension**



**Telescopic extension**





## GATE VALVES

### Pressure Testing Procedure

In accordance with: EN 12266-1 (DIN3230-3) / ISO5208

**Scope:** On/Off Gate Valves, Globe Valves, Ball Valves, Plug Valves, Butterfly Valves, Diaphragm Valves. Manual and Actuated.

#### 1. Shell strength (Test ref. P10) and Shell tightness (Test ref. P11)

**- Purpose:**

P10 to confirm the pressure containing capability of the shell against internal pressure.

P11 to confirm leak tightness of the shell including the operating mechanism sealing against internal pressure.

**- Test medium:**

Water with a corrosion inhibitor, ambient temperature 5-50°C

**- Test method:**

Move the valve to a partially open position.

Black off the ends of an assembled valve and fill the cavities with the test fluid.

Apply 1,5 times the allowable pressure (valve PN) with test duration as follows:

Up to DN50	15 s
from DN65 to DN200	60 s
DN250 and larger	180 s

**- Acceptance criteria:**

Visually detectable leakage through the pressure containing walls is not permitted.

#### 2. Seat tightness (Test ref. P12)

**- Purpose:**

P12 to confirm the capability of the seat to conform to the specified leakage rate during manufacture and in the direction(s) for which the valve is designed.

**- Test medium:**

Water with a corrosion inhibitor, ambient temperature 5-50°C

**- Test method:**

Fill the valve cavity with the test fluid.

**Manual valves:**

Move the valve to the closed position by means of its manual device.

Apply 1,1 times the allowable pressure (valve PN) with test duration as specified below.

	Metal Seating	Soft Seating
Up to DN50	15 s	15 s
DN65 to DN200	30 s	15 s
DN250 to DN450	60 s	30 s
DN500 and larger	120 s	30 s



## GATE VALVES

### Pressure Testing Procedure

#### **Actuated valves:**

Move the valve to the closed position by means of its actuator as follows:

- Pneumatic actuators, air to open - spring to close valves: vent all the air from the actuator chamber making sure that the valve has reached its fully closed position.
- Pneumatic actuators, air to close – spring to open valves and double acting type: apply the specified actuator air supply pressure and wait until the valve has reached its fully closed position.
- Electric actuators – connect the actuator to extend the valve stem until the valve has reached its fully closed position.

Apply pressure inside the valve according to the maximum closing pressure offered by the valve-actuator combination with test duration as specified below.

	Metal Seating	Soft Seating
Up to DN50	15 s	15 s
DN65 to DN200	30 s	15 s
DN250 to DN450	60 s	30 s
DN500 and larger	120 s	30 s

#### **- Acceptance criteria:**

Rate A. "No visually detectable leakage" means no visible weeping or formation of drops for soft seating on-off valves.

Rate CC.  $0,08 \times \text{DN mm}^3/\text{s}$  or  $0,0013 \times \text{DN drops/s}$  for metal seating on-off valves.

#### **NOTES:**

1) TESTS P10-P11, only metal pressure containing parts are obliged to bear with 1,5 PN test pressure. Valves with already mounted soft parts such as diaphragms could be tested at 1,1 PN under manufacturer criteria.

2) TESTS P10-P11-P12 Lower pressure tests can be agreed between supplier and purchaser in relation to working conditions.



## GATE VALVES

### IOM - Installation and Maintenance Guidelines

#### INSTALLATION

Bear in mind the following guidelines along with general installation practice:

- Check the equipment design codes in relation with the applicable plant codes.
- Ensure that pressure design, temperature design, valve construction materials compatibility and other essential parameters conform with the duty.  
(Check operating limits on the Data Sheets and valve marking)
- Consider the interaction between the system and the equipment. Foresee elements to absorb vibrations, pipe dilatations, guides, anchoring and proper support according to the weight of the components.
- The system should be designed in such a way to avoid high velocities (max. 4 m/s or lower in case of abrasive media), pulsing flow or water hammers, which are very harmful for valves and the rest of the components.
- Allow enough space for maintenance operations.
- **Installation position:** The valves are bi-directional. Otherwise, for some special configuration, there is an arrow on the body pointing out the flow direction to be followed. Valve optimal position is horizontal with stem pointing upwards. Small sizes can alternatively be installed in vertical pipelines. Always avoid the stem pointing downwards.
- Protect the valve soft parts from heating caused by welding works at the plant during commissioning.
- Protect the valves from dirt during installation and start-up works. Remove protective caps, remaining package, etc. if any just before installation and check that the valve is clean of foreign particles.
- It is essential to flush the pipe system thoroughly to eliminate all the particles and impurities which could remain in the pipes and particularly welding residue, chips, tool remains, etc. that could damage the equipment during start-up. Ensure that during cleaning of the pipe system, any chemicals used and temperature are compatible with the valve construction.
- It is recommended to install a proper sized mesh strainer upstream the valve in order to protect seating surfaces from abrasion or erosion that could lead to seat leakage.
- If required by the customer, gate valves from DN150 can be equipped with a bypass to provide equalization of upstream and downstream pressures.

#### FOR FLANGED VALVES:

- Make sure that counter-flanges are compatible with the standard of the valve flanges. When matching up flanges, avoid gradients, rotation and pipe misalignment that could cause pipe and valve stress and leakage once installed. Flanges should fit smoothly. Select the proper flange face gaskets according to duty and centre them on the flange face properly. Do not force the counter-flanges and do not try to tighten the bolts when a gap exists between valve and pipe or if misalignment is observed. Tighten in a crosswise, moderate and uniform manner. During start-up tighten again if leakage is noticed or replace gasket if necessary.

#### FOR SCREWED END VALVES:

- Make sure that the pipe screw has the correct finish and compatible cone for the valve.
- Use proper sealant according to duty, such as hemp core, Teflon, etc.
- Check that pipe introduction in the valve does not exceed its thread, leave a safety margin of minimum 1 mm.
- Tighten with a plain or adjustable wrench on the hexagon end of the valve only. Apply force to other area of valve may seriously damage the valve. Do not use hook spanners or other wrenches that could damage the hexagon surface. Valve should be threaded smoothly. If not, do not try to force the thread and avoid wrench extensions since this could lead to breaking the valve or damaging the thread. A general recommendation is not to exceed the tightening torque of 30Nm.



## GATE VALVES

### IOM - Installation and Maintenance Guidelines

**ACTUATOR:** If the valve requires pneumatic, electric or hydraulic actuators, separate actuator IOMs shall be also followed.

To avoid unnecessary stress and risk of valve break, weight of actuator should be properly supported in case the valve stem is not pointing upwards.

Make sure that the actuator is suitable for service particular requirements, valve adaptability, function needed, adequate torque for the valve, need for limit switches, etc. Contact our Technical Department for advice.

### START-UP

- Once the valve installed, make an initial opening and closure manoeuvre to check its proper operability.

- Valve operation, filling, warming-up and starting-up shall be gradual so as to avoid any inadmissible stress.

Check for tightness in valve connections, body/bonnet union, and stem, and retighten crosswise and gradually if necessary until leakage elimination. For valves with packing make sure that operating torque is not significantly affected by flange gland over tightening. If leakage persists surfaces should be thoroughly cleaned and new gaskets or packing rings correctly placed.

- **Warning!** For valves with packing, it is tightened at factory in a moderate way to pass the pressure tests. After a while before installation, packing rings experiment a relaxation and some retighten could be needed during start-up. Over tightening the bolts will increase operating torque. Also after several open and close manoeuvres of the valve the stem gains some play with the packing rings, thus packing tightness should be checked periodically and retighten gradually when necessary.

- **Warning!** Temperatures above 50°C or below 0°C may cause personnel injuries if valves are touched. Ensure that the corresponding warning signs are displayed on the valve or surrounding area, or isolate the equipment in case of danger.

IT IS THE RESPONSIBILITY OF THE INSTALLER / OPERATOR TO ENSURE THAT ALL HEALTH & SAFETY REQUIREMENTS ARE FOLLOWED AS LAID DOWN BY THE CONTROLLING COMPANY.

### MAINTENANCE AND SPARE PARTS

Maintenance and corresponding intervals between them, should be defined and scheduled by the plant operation personnel according to service level.

In the event of infrequent use, ensure that the valve exposed stem keeps lubricated and operate the valve as frequently as possible to avoid deposits of dirt and valve blocking.

Check for body and seat tightness and valve smooth operation without additional tools.

Wait for the valve medium to cool down before starting any maintenance work at the plant, release the pressure from the system, drain the line and pipe system in the event of toxic, corrosive, flammable or caustic fluids.

Check the valve surface inside and outside. If advanced corrosion or erosion is observed double check service and valve features and replace the valve properly.

In case of body/bonnet leakage, dismount the bonnet, remove old gasket, clean sealing surfaces and use a new gasket.

In case of seat leakage, remove the valve bonnet to clean the seating surfaces. When mounting the bonnet again use always new gasket, and tighten the bonnet bolts evenly crosswise with moderate and uniform torque. Retighten them if leakage is detected under pressure.

If it is not possible to repair the damages replace the valve and contact us for assistance.

If the valve is leaking through the stem:

- For valves with stem tightness with O-rings, remove the old ones, clean sealing surfaces and mount the new ones applying silicone grease to ease mounting and lubrication. If the sealing surfaces are damaged they should be changed.



## GATE VALVES

### IOM - Installation and Maintenance Guidelines

- For valves with stem tightness with packing, try first to retighten the packing without compromising stem smooth movement. If leakage cannot be corrected, old packing must be replaced.

Remove packing gland, remove old packing by means of a wooden dowel, make sure that stem and packing area are thoroughly cleaned and place new packing rings ensuring its correct position. If stem is worn out or scratched replace it. Then place again packing gland and tighten gland bolts moderately. Test the valve under pressure and if necessary retighten gradually until leakage disappears (see also warning 1 in Start-Up chapter).

Some models have back seat feature (consult with our technical department for advice), in such a case packing can be dismantled in line under pressure after fully opening the valve. Anyway we strongly recommend to always release the pressure and cool down the system before any maintenance work, and drain the system specially if dangerous medium is involved.

After any maintenance work please refer to START-UP chapter.

Recommended Spare parts:

We strongly recommend to use genuine spare parts.

It is advisable to keep packing rings and body/bonnet gaskets as spare parts. Other spare parts available are stem, stem nut, packing gland, gate, etc. Type and number of each spare part to be stored according to service level and valves quantity. In many cases the best choice is to keep complete valves as spare part.

For particular valve specification and parts description and materials, please refer to the corresponding approved order drawing.

### TROUBLESHOOTING TABLE.

FAULT	POSSIBLE CAUSE	CORRECTING MEASURES
No flow Not enough flow	Flange covers or protection not removed. Valve closed or almost closed. Piping clogged.	Clear valve entrances. Check valve position. Check piping system.
Broken flange	Bolts not properly tightened. Mating flanges not properly aligned.	Re-align piping and fit new valve.
Leakage between body and bonnet	Bonnet bolts loose or gasket damaged.	Retighten bonnet bolts or change gasket.
Leakage through the stem	Stem O-rings worn out Gland packing bolts loosen. Packing worn out.	Replace O-rings Retighten bolts. Replace packing.
Valve not tight at closing	Valve is not in closed position. Dirt in the seal. Seat surfaces damages. Too much pressure.	Check correct handwheel rotation. Clean the dirt. Machine seat or change seating parts. Check the system.
Too high operating torque, handwheel hard to turn	Packing too tight. Gland flange badly assembled. Stem or nut thread damage or with dirt. Stem is bended.	Check packing. Check gland flange assembly. Inspect and replace/clean parts. Replace stem.



## GATE VALVES

### Valves Assembling Set

DN	Bolts with nuts		Flanges PN10	Gaskets
	Quantity	Size	Quantity	Quantity
15	8	M12x45	2	2
20	8	M12x50	2	2
25	8	M12x50	2	2
32	8	M16x55	2	2
40	8	M16x55	2	2
50	8	M16x60	2	2
65	8	M16x60	2	2
80	16	M16x65	2	2
100	16	M16x65	2	2
125	16	M16x70	2	2
150	16	M20x75	2	2
200	16	M20x80	2	2
250	24	M20x80	2	2
300	24	M20x80	2	2
350	32	M20x90	2	2
400	32	M24x90	2	2
450	40	M24x100	2	2
500	40	M24x100	2	2



DN	Bolts with nuts		Flanges PN16	Gaskets
	Quantity	Size	Quantity	Quantity
15	8	M12x45	2	2
20	8	M12x50	2	2
25	8	M12x50	2	2
32	8	M16x55	2	2
40	8	M16x55	2	2
50	8	M16x60	2	2
65	8	M16x60	2	2
80	16	M16x65	2	2
100	16	M16x65	2	2
125	16	M16x70	2	2
150	16	M20x80	2	2
200	24	M20x80	2	2
250	24	M24x90	2	2
300	24	M24x90	2	2
350	32	M24x100	2	2
400	32	M27x100	2	2
450	40	M27x100	2	2
500	40	M30x110	2	2
600	40	M33x140	2	2



## GATE VALVES

### Valves Assembling Set

DN	Bolts with nuts		Flanges PN25	Gaskets
	Quantity	Size	Quantity	Quantity
15	8	M12x50	2	2
20	8	M12x55	2	2
25	8	M12x55	2	2
32	8	M16x55	2	2
40	8	M16x55	2	2
50	8	M16x60	2	2
65	16	M16x65	2	2
80	16	M16x70	2	2
100	16	M20x70	2	2
125	16	M24x80	2	2
150	16	M24x90	2	2
200	24	M24x90	2	2
250	24	M27x100	2	2
300	32	M27x100	2	2
350	32	M30x110	2	2
400	32	M33x120	2	2
450	40	M33x130	2	2
500	40	M33x130	2	2
600	40	M36x150	2	2



DN	Bolts with nuts		Flanges PN40	Gaskets
	Quantity	Size	Quantity	Quantity
15	8	M12x50	2	2
20	8	M12x55	2	2
25	8	M12x55	2	2
32	8	M16x55	2	2
40	8	M16x55	2	2
50	8	M16x60	2	2
65	16	M16x65	2	2
80	16	M16x70	2	2
100	16	M20x70	2	2
125	16	M24x80	2	2
150	16	M24x90	2	2
200	24	M27x100	2	2
250	24	M30x110	2	2
300	32	M30x120	2	2
350	32	M33x130	2	2
400	32	M36x140	2	2
450	40	M36x150	2	2
500	40	M39x150	2	2
600	40	M45x190	2	2



